

SELECTRONIC® Micro-Controller



Series 1500

- Alarm/Shutdown for 32 N.O. and/or N.C. Sensors
- Operating Sequence Selection
- Completely Field Adjustable
- Selectable Sensor Lockouts Class A, B, C or P
- Built-In Tachometer/Overspeed Function
- Clearly Visible Alphanumeric Display
- RS232 Communications Capability
- Two Start/Run Timers
- Elapsed Time Meter



Approved for Class I,
Division 1 Groups C & D

Description

The Series 1500 is a microprocessor based alarm and/or shutdown system. It tells in alphanumeric characters which protective device has signaled an alarm or caused equipment shutdown. Basic configuration for each application is programmed at Murphy and can be configured in the field. Information is called up and adjustments are made on a six-button keypad on the face of the unit.

The **S1500** system consists of a monitor, a sensor input terminal strip (rail mount type), a 36 inch (914 mm) flat ribbon cable for connecting the terminal strip to the monitor, and a power supply which includes the control Inputs/Outputs and intrinsically safe barrier with cable assembly.

Four SPDT relays are available for alarm and/or shutdown functions. A built-in RS232 communication port allows interfacing with IBM® PC and compatible computer systems and micro-controllers.

The S1500 is powered from a 120 VAC or 12 or 24 VDC, Class I, Division 1 explosion-proof power supply. The monitor is rated intrinsically safe.

Intrinsically Safe Barrier

Murphy's LCDT-**ISB** intrinsically safe barrier for hazardous applications, is designed for use with two Normally Open sensors. This external barrier accepts non-intrinsically safe, normally open inputs and converts them to intrinsically safe outputs.

Applications

The Series 1500 can be configured to monitor applications such as:

- Generators
- Air compressors
- Gas compressors
- Fire pumps
- Sewage pumps
- Process control
- Water treatment
- Burner systems
- Natural gas refueling

Features

- 32 sensor inputs (N.O. and/or N.C.) for alarm or shutdown.
- Six-button keypad for easy operation and adjustments.
- RS232 output for interface with computers and micro-controllers (modem required).
- Engine Automatic.
- Two Start-Run Timers.
- Four Control Relay Outputs.
- Pre/Postlube Time Delay.
- Typical standard program or customized*

* Murphy provides various standard preprogrammed configurations. If a customer sensor input configuration is needed, Murphy will custom program your unit at the time you order. Call Murphy for quote.

Warranty

A two-year limited warranty on materials and workmanship is given with this Murphy product. Details are available on request and are packed with each unit.

How to Order

To order the Complete S1500 System: Monitor, Terminal Block, Cable Assembly and Power Supply, just specify the part number:

S1500

To order individual components and accessories specify model number:

Specify:	To Order:
S1500H	Monitor (Head) only
S1500TB32	Terminal Block only
S1500CA36	Cable Assembly only
S1500PS	Power Supply only
LCDT-ISB	Intrinsically Safe Barrier (for Normally Open Sensors*)

Shipping Weights and Dimensions

Complete S1500 System:	28 lb. [12.7 kg.]; 20 x 14 x 12-1/2 in. [508 x 356 x 318 mm].
S1500 H:	2 lb. (0.907 kg.); 6 x 6 x 6 in. (152 x 152 x 152 mm).
S1500 TB32:	2 lb. (0.907 kg.); 12 x 7 x 4 in. (305 x 178 x 102 mm).
S1500CA36:	2 lb. (0.907 kg.); 6 x 6 x 6 in. (152 x 152 x 152 mm).
S1500PS:	22 lb. (9.98 kg.); 17 x 10 x 9-3/4 in. (431 x 254 x 248 mm).
LCDT-ISB:	3 lb. (1.3 kg.); 9 x 10 x 6 in. (229 x 254 x 152 mm).

* For Normally Closed sensor the use an intrinsically safe (approved) barrier is required.

Specifications

Series 1500 System

Power Consumption: 120 VAC (8 watts), 12 or 24 VDC (2.5 or 7.2 watts).

Sensor Inputs: 32 N.O. and/or N.C., such as Murphy SWICHGAGE® instruments. Inputs are factory-programmed as a Class A, B, C or P for shutdown, alarm, or control function (specify).

Opto-Isolated Input: 12-120 VDC or 24-120 VAC, the opto-isolated input is typically used as a run input, magnetic pickup and ignition.

Outputs: 4-SPDT relays, 4 A, $\frac{1}{20}$ HP, 125/250 VAC/3A, 30 VDC.

NOTE: An approved isolation barrier must be used between the sensor switch and input terminals if the sensor output comes from any energy storing device such as a relay or transistor. (See LCDT-ISB Barrier, at right).

Timers: 12 adjustable timers for:

- Two Start-up lockouts
- Postlube
- Crank
- Process delay
- Test
- Load delay
- Rest
- Ignition ground
- Prelube
- Idle
- Run delay

Time Delay: Delay before ignition ground or electric motor stop, for up to 59 seconds.

Terminal Block: Rail mount DIN type; 32 positions (screw type).

Backup Battery: Rechargeable during normal operation. Provides up to 5 hours backup time.

Tachometer Sensing: From either CD Ignition or Magnetic Pickup.

Operating Temperatures: 32 to 122°F (0 to 50°C).

Storage Temperatures: -4 to 158°F (-20 to 70°C).

Case: ABS plastic, $\frac{1}{4}$ DIN (90 x 90 mm).

Interface Output: RS232 communication port.

Alphanumeric Display: 2 lines, each line with 16 characters (32 total).

Laboratory Approvals: CSA and NRTL/C for Cl. I, Div. 1, Grps. C & D.

Power Supply Enclosure: Explosion-proof, Class I, Division 1. Intrinsically safe barrier built into power supply, 120 VAC and 12 or 24 VDC power supply barrier with dry contact relay functions such as:

- Fuel valve
- Shutdown
- Control (Pre/Postlube)
- Engine Cranking
- Alarm
- Ignition
- Compressor Loading

LCDT-ISB Intrinsically Safe Barrier:

External barrier explosion-proof design for hazardous locations, according to NEC requirements for Class 1, Division 1 Group D areas. The LCDT-ISB accepts Normally Open sensor inputs (2 inputs per barrier). For Normally Closed sensors, an intrinsically safe (approved) barrier is required.

Dimensions

Module, Terminal Block, Power Supply

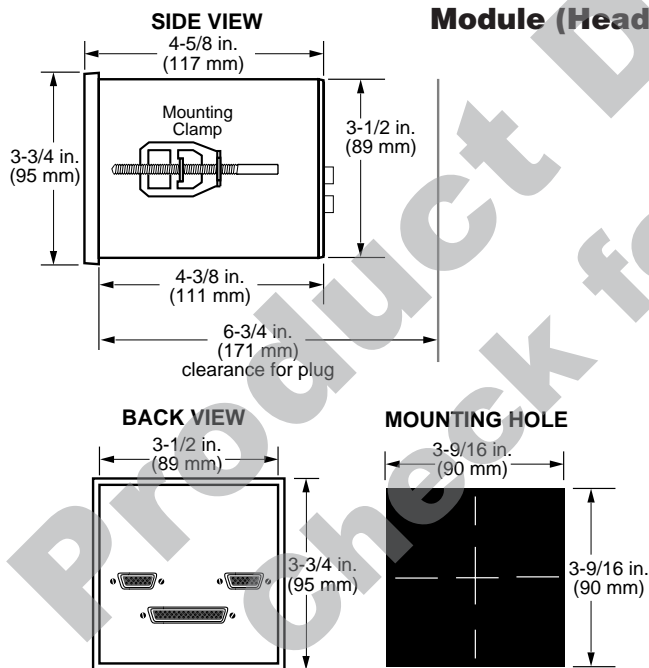

Terminal Block

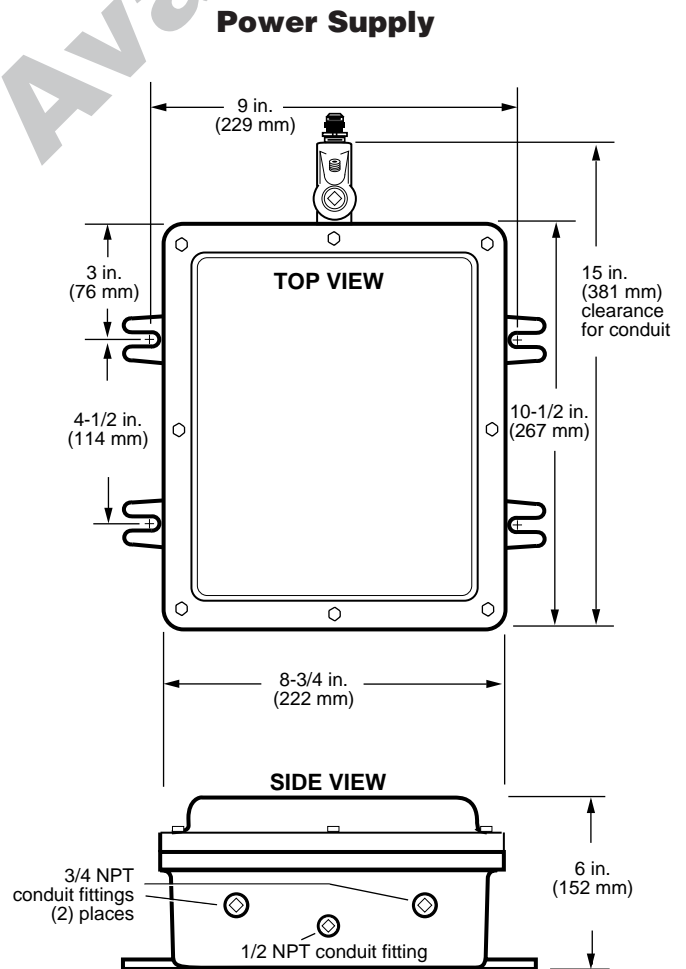
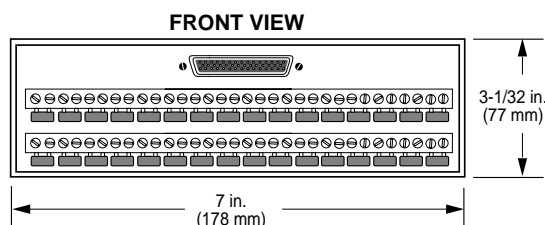

Use the listings below to specify sensor input Class, Function and Nomenclature; the S1500 sensor inputs are factory-configured as follows:

Class A: Armed at all times for alarm or shutdown (specify).

Class B1: Locked out by first lockout timer (First Start/Run timer).

Class B2: Locked out by second lockout timer (Second Start/Run timer).

Class C: Armed after fault condition has been cleared for 2 seconds.

Class P: Locked out by the Compressor Load lockout timer.

ESD: Overrides the Test lockout timer (for Remote/Emergency Stop input).

SD: S1500 System Shutdown Function.

AL: Alarm Relay Function (no shutdown).

Sensor Input	Specify Class	Specify Function	Default Nomenclature	User Specified Nomenclature
Example:	<u>Class B2</u>	<u>SD</u>	<u>Compressor Oil Pressure</u>	<u>Compressor #1 Oil Pressure</u>
Input 1	_____	_____	Compressor Oil Pressure	_____
Input 2	_____	_____	Compressor Oil Level	_____
Input 3	_____	_____	Lubrication No-Flow	_____
Input 4	_____	_____	Low Suction Pressure	_____
Input 5	_____	_____	Interstage Pressure #1	_____
Input 6	_____	_____	Interstage Pressure #2	_____
Input 7	_____	_____	Interstage Pressure #3	_____
Input 8	_____	_____	Discharge Pressure	_____
Input 9	_____	_____	Discharge Temperature #1	_____
Input 10	_____	_____	Discharge Temperature #2	_____
Input 11	_____	_____	Discharge Temperature #3	_____
Input 12	_____	_____	Discharge Temperature #4	_____
Input 13	_____	_____	Suction Liquid Level	_____
Input 14	_____	_____	Interstage Liquid Level #1	_____
Input 15	_____	_____	Interstage Liquid Level #2	_____
Input 16	_____	_____	Interstage Liquid Level #3	_____
Input 17	_____	_____	Inlet Scrubber Liquid Level	_____
Input 18	_____	_____	Engine Oil Pressure	_____
Input 19	_____	_____	Engine Oil Level	_____
Input 20	_____	_____	Engine Oil Vibration	_____
Input 21	_____	_____	Engine Jacket Water Temp.	_____
Input 22	_____	_____	Engine Jacket Water Level	_____
Input 23	_____	_____	Engine Jacket Water Press.	_____
Input 24	_____	_____	Engine Vacuum Right Bank	_____
Input 25	_____	_____	Engine Vacuum Left Bank	_____
Input 26	_____	_____	Compressor Vibration	_____
Input 27	_____	_____	Cooler Vibration	_____
Input 28	_____	_____	Cooler Water Level	_____
Input 29	_____	_____	Auxiliary Pump Shutdown	_____
Input 30	_____	_____	Emergency Shutdown	_____
Input 31	_____	_____	PLC Shutdown	_____
Input 32	_____	_____	Prelube Permissive	_____

Select your Relay Logic Mode (see page 4):

MODE No. _____

Select your Timing and range; (default values)

TACHOMETER

Pulses/Rev.: _____ (60)

Crank Disconnect: _____ (100)

Underspeed: _____ (150)

Overspeed: _____ (400)

TIMERS

Prelube: _____ (0:30)

Run Delay: _____ (0:30)

Class B1: _____ (1:00)

Class B2: _____ (1:00)

Load Delay: _____ (1:00)

Process Delay: _____ (1:30)

Idle/Cooldown: _____ (5:00)

Ignition Ground: _____ (0:10)

Postlube: _____ (0:30)

CRANKING

Attempts: _____ (5)

Crank Period: _____ (0:15)

Rest Period: _____ (0:15)

Mode Chart

Relay / Logic Mode Configurations Available

Logic Modes	Motor	Ignition	Cooler	Load	Shutdown	Lube	Crank	Alarm	Fuel
Mode 01		K4	K3	K2			K1		
Mode 02		K4		K3		K2	K1		
Mode 03		K4	K3			K2	K1		
Mode 04		K4	K3	K1		K2			
Mode 05		K4		K2	K3		K1		
Mode 06		K4	K2		K3		K1		
Mode 07		K4	K2	K1	K3				
Mode 08		K4			K3	K2	K1		
Mode 09		K4		K1	K3	K2			
Mode 10		K4	K1		K3	K2			
Mode 11		K4		K3			K2	K1	
Mode 12		K4	K3				K2	K1	
Mode 13		K4	K3	K2				K1	
Mode 14		K4				K2	K3	K1	
Mode 15		K4		K3		K2		K1	
Mode 16		K4	K3			K2		K1	
Mode 17		K4			K3		K2	K1	
Mode 18		K4		K2	K3			K1	
Mode 19		K4	K2		K3			K1	
Mode 20		K4			K3	K2		K1	
Mode 21		K4		K2			K1		K3
Mode 22		K4	K2				K1		K3
Mode 23		K4	K2	K1					K3
Mode 24		K4				K2	K1		K3
Mode 25		K4		K1		K2			K3
Mode 26		K4	K1			K2			K3
Mode 27		K4			K2		K1		K3
Mode 28		K4		K1	K2				K3
Mode 29		K4	K1		K2				K3
Mode 30		K4			K1	K2			K3
Mode 31		K4					K2	K1	K3
Mode 32		K4		K2				K1	K3
Mode 33		K4	K2					K1	K3
Mode 34		K4				K2		K1	K3
Mode 35		K4			K2			K1	K3
Mode 36	K4		K3	K1		K2			
Mode 37	K4		K2	K1	K3				
Mode 38	K4			K1	K3	K2			
Mode 39	K4		K1		K3	K2			
Mode 40	K4		K3	K2				K1	
Mode 41	K4			K3		K2		K1	
Mode 42	K4		K3			K2		K1	
Mode 43	K4			K2	K3			K1	
Mode 44	K4		K2		K3			K1	
Mode 45	K4				K3	K2		K1	

In order to consistently bring you the highest quality, full featured products, we reserve the right to change our specifications and designs at any time.



■ **Frank W. Murphy Manufacturer**
 P.O. Box 470248; Tulsa, Oklahoma 74147; USA
 tel. (918) 627-3550 fax (918) 664-6146
 e-mail fwmmurphy@ionet.net

■ **Frank W. Murphy Southern Division**
 P.O. Box 1819; Rosenberg, Texas 77471; USA
 tel. (281) 342-0297 fax (281) 341-6006
 e-mail murphysd@intertex.net

■ **Frank W. Murphy, Ltd.**
 Church Rd.; Laverstock, Salisbury SP1 1QZ; U.K.
 tel. +44 1722 410055 fax +44 1722 410088 tlx 477088
 e-mail sales@fwmurphy.co.uk

■ **Frank W. Murphy Pte., Ltd.**
 26 Siglap Drive; Republic of Singapore 456153
 tel. +65 241-3166 fax +65 241-8382
 e-mail fwmsales@fwmurphy.com.sg

■ **Murphek Pty., Ltd.**
 1620 Hume Highway; Campbellfield, Vic 3061; Australia
 tel. +61 3 9358-5555 fax +61 3 9358-5558

■ **Murphy de México, S.A. de C.V.**
 Blvd. Antonio Rocha Cordero 300, Fracción del Aguaje
 San Luis Potosí, S.L.P.; México 78384
 tel. +52-48-206264 fax +52-48-206336
 e-mail murmexsl@infosel.net.mx

■ **Murphy Switch of California**
 P.O. Box 900788; Palmdale, California 93590; USA
 tel. (805) 272-4700 fax (805) 947-7570
 e-mail sales@murphyswitch.com

■ **Frank W. Murphy France**
 tel. +33 1 30 762626 fax +33 1 30 763989