



Installation for L1100, L1200, L1200N Series Liquid Level Switches and DVU150, DVU175, and DVU2105/2115/2120 Series Dump Valves.

Please read the following instructions before installing. A visual inspection for damage during shipping is recommended before mounting.

GENERAL INFORMATION

WARNING

BEFORE BEGINNING INSTALLATION OF THIS MURPHY PRODUCT

- ✓ Disconnect all electrical power to the machine.
- ✓ Make sure the machine cannot operate during installation.
- ✓ Follow all safety warnings of the machine manufacturer.
- ✓ Read and follow all installation instructions.
- ✓ OBSERVE all pressure and electrical ratings and requirements for the devices and the operating environment.
- ✓ BE SURE all pressure HAS BEEN REMOVED from the vessel before opening any pressure connections.

Description

Series L1100 and L1200 Liquid Level Switches are float activated to operate an electrical SPDT snap switch (optional DPDT on some models) for alarm or shutdown of an engine or electric motor. They screw directly into the wall of the vessel. Series L1200 can also be used with a weld collar or external float chamber.

Series L1200N is a float-activated, pneumatic-vent level device used to operate dump valves or similar devices. This model screws directly into the vessel or can be mounted via an external float chamber. It **cannot** be used with weld collar 15050375. Model variations include a dump valve operator with or without a filter/pressure regulator and indicating pressure gauge.

NOTE: All stainless steel versions of L1100, L1200, L1200N, L1200NDVO, and L1200NDVOR series carry Canadian Registration Number OF1476.2.

Series DVU150, DVU175, DVU2105/2115/2120 Dump Valves receive a pneumatic input signal to cause an orifice to open or close allowing liquid condensate to be drained from a pressure vessel. A pop up button indicates valve open/closed. Stainless steel versions available.



Specifications	L1100	L1111	L1200	L1200N	L1200NDVO	L1200NDVOR
Body						
• Standard: Electroless Nickel plated steel	X ^A	X ^A	X ^B	X ^B	X ^B	X ^B
• Optional: 316 Stainless Steel [†]	X ^A	X ^A	X ^B	X ^B	X ^B	X ^B
Pressure Rating						
• 15 psi (103 kPa) [1.03 bar] Polyethylene Float						
• 1500 psi (10.3 MPa) [103.42 bar] Stainless Float	X	X	X	X	X	X
• 2000 psi (13.8 MPa) [138 bar] BUOYGLAS™ Float	X	X	X	X	X	X
Temperature Rating						
• Standard: -20/175°F (-29/79°C)						
• Standard: -20/300°F (-29/149°C)	X	X	X	X	X	X
• Optional: -20/400°F (-29/204°C)*	X		X	X	X	X
Specific Gravity						
• Standard: 0.5 with BUOYGLAS™ float	X	X	X	X	X	X
• Optional: 0.65 with 304 Stainless Steel [†]	X		X	X	X	X
• Standard 0.73 Polyethylene Float						
Electrical						
• Standard SPDT: 5 A @ 125/480 VAC (see p. 3 for full ratings)	X	X	X			
• Optional DPDT: 10 A @ 250 VAC (see p. 3 for full ratings)	X	X	X			
Wire: 18 AWG x 36 in. (1.0 mm ² x 914 mm)	X	X	X			
O-Rings: Viton	X	X	X	X	X	X
Valve: Two-way snap-action vent type • 1/8 in. (3 mm) orifice w/Viton "A" seat • 1/8 NPT inlet; 1/4 NPT vent • 30-70 psi (207-483 kPa) [2.07-4.83 bar] operating pressure				X	X	X
Dump Valve Operator: Operates Murphy DV Series dump valves or similar. 1/8 NPT inlet, outlet & vent.					X	X
Pressure Regulator/Filter and Murphy 20BPG: 0-75 psi (0-517 kPa) [0-5.17 bar] pressure gauge. Maximum input 300 psi (2.07 MPa) [20.68 bar]. 1/8 NPT in/out.						X
Operation: H=For high level, L=For low level	H	L	H	H	H	H

^A=1-1/2 NPT

^B=2 NPT

[†]Meets NACE standard MR-01-75 for direct exposure to H₂S service.

*Not available with DPDT snap-switch.

**Products covered by this literature comply with EMC Council directive 89/336/EEC regarding electromagnetic compatibility.

DIMENSIONS

L1100 and L1200

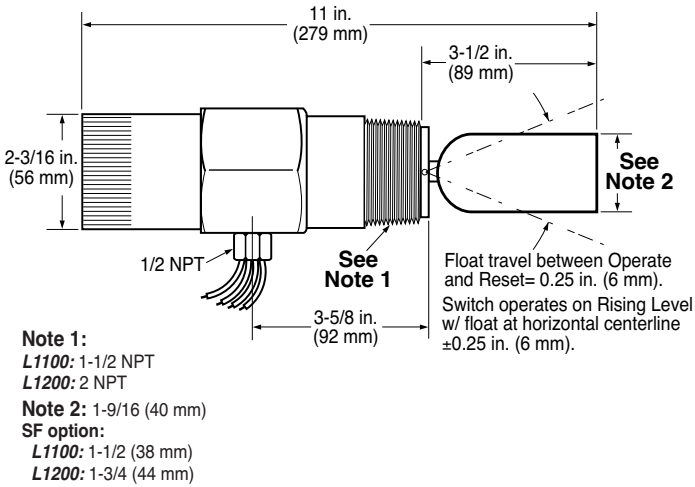

L1111

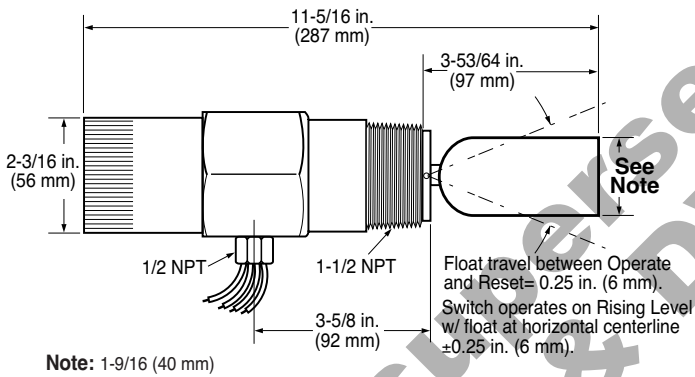

Electrical installation to be done by qualified person according to the NEC.

L1200N, L1200NDVO and L1200NDVOR with Dump Valve Operator, Pressure Regulator and Gage

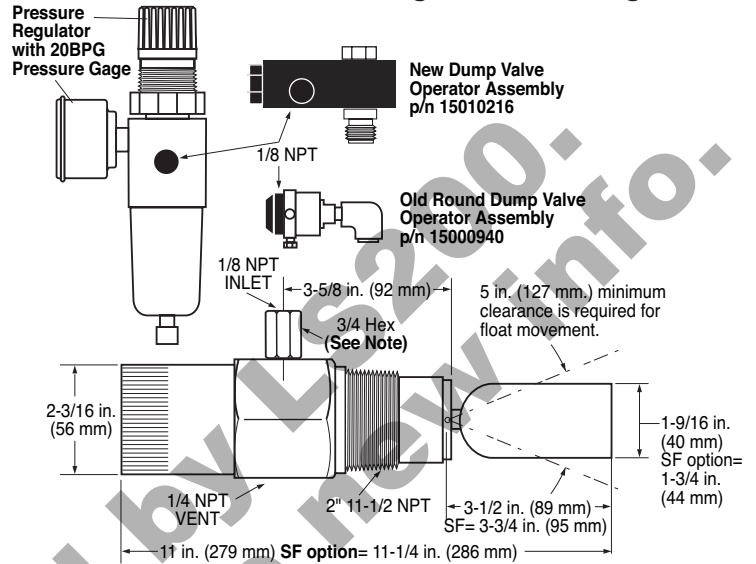

DVU150, DVU175, DVU2105/2115/2120 Series Dump Valves

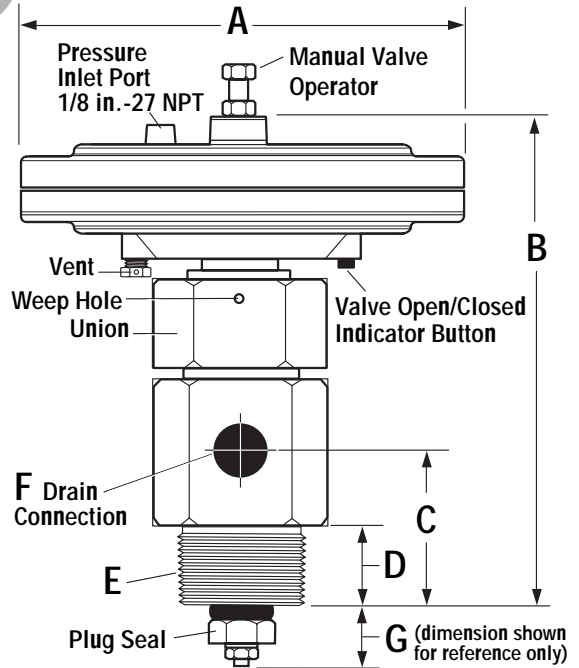

Model	A	B	C	D	E	F	G
DVU2120	7.50 (191)	8.0 (203)	2.75 (70)	1.0 (25)	2-11.5 NPT	1-11.5 NPT	1.03
DVU2115	7.50 (191)	8.0 (203)	2.75 (70)	1.0 (25)	2-11.5 NPT	1-11.5 NPT	1.03
DVU2105	7.50 (191)	8.0 (203)	2.75 (70)	1.0 (25)	2-11.5 NPT	1-11.5 NPT	1.03
DVU175	7.50 (191)	6.75 (171)	2.06 (52)	1.0 (25)	1-11.5 NPT	3/4"-14 NPT	1.03
DVU150	7.50 (191)	6.75 (171)	2.06 (52)	1.0 (25)	1-11.5 NPT	1/2"-14 NPT	1.03

NOTE: Dimensions are in inches and (millimeters)

REPLACING AND INSTALLING THE DVOA ASSEMBLY

When replacing/installing the old style DVO assembly with the new style (DVOA), tubing and fitting modifications are required. We suggest removing the L1200NDVO/DVOR from the vessel. Relieve pressure from the vessel or use block valves before removing the L1200NDVO/DVOR.

Replacing and Installing the DVOA Assembly For Models L1200NDVO & L1200NDVOR

Tools Needed: Strap or pipe wrench; 3/4" Hex wrench; 9/16" hex wrench; needle nose pliers; tubing cutters and benders and the appropriate tools for the fittings.

NOTE: Clean, dry instrument quality gas should be used. Use of filters will improve service life and reliability.

1. Block off and bleed the instrument gas pressure supply to the L1200NDVO.
2. Remove the tubing between the L1200NDVO and the separator dump valve, and remove the supply gas tubing (regulator [-R] if used).
3. Remove the L1200NDVO from the vessel (optional).
4. If the L1200N was removed from the vessel, mount it in a suitable vise on a work bench (if possible).
5. Using the proper tools, disconnect the Inlet, Outlet and Exhaust fittings from the existing DVO (see fig. 1). You will re-connect these to the new DVOA in a later step.

NOTE: The following steps must be done with the DVO in the upright position (on top of the L1200N).

6. Remove the L1200N cover (this will aid with the alignment of the new DVOA Valve Bushing). The use of a strap wrench or a pipe wrench may be needed.
7. Insert the new Valve Bushing through the new DVOA (see fig. 2). The markings on top of the DVOA must be facing up. This will be needed in step 9.
8. With a 3/4" hex wrench loosen the existing DVO, valve stem, and static seal (see fig. 3). Once the assembly is loosened, **VERY CAREFULLY** use needle nose pliers to hold the Valve Seat Assembly in place. Remove the existing DVO making sure the Valve Seat Assembly inside the L1200NDVO is aligned and straight (see fig. 4).



CAUTION: MAKE SURE the Valve Seat Assembly inside the L1200N remains in place after removing the DVO.

9. Holding the Seat Assembly up with the needle nose pliers inside the L1200NDVO body, place the tip of the new DVOA valve bushing through the spring and into the hole in the center of the valve seat, and tighten the valve bushing. The Valve Seat Assembly should be able to move freely up and down after the bushing has been tightened. The DVO red button must face away from the vessel.
10. With the new DVOA aligned over the hex on the L1200NDVO body, tighten the Valve Bushing using the 9/16" hex wrench. You may need to hold the DVOA while tightening the Valve Bushing to keep it from rotating (see fig. 5).
11. If the L1200N is in the vise, operate the float and inspect for smooth and proper operation of the Valve Seat Assembly.
12. Replace the L1200NDVO cover (see fig. 6).
13. Using the appropriate tools re-install the Inlet, the Outlet and the Exhaust fittings to the new DVOA (see fig. 5).
14. If the L1200N was removed from the vessel re-install it at this time.
15. Modify existing or install new tubing to connect the Inlet, the Outlet and Exhaust fittings.

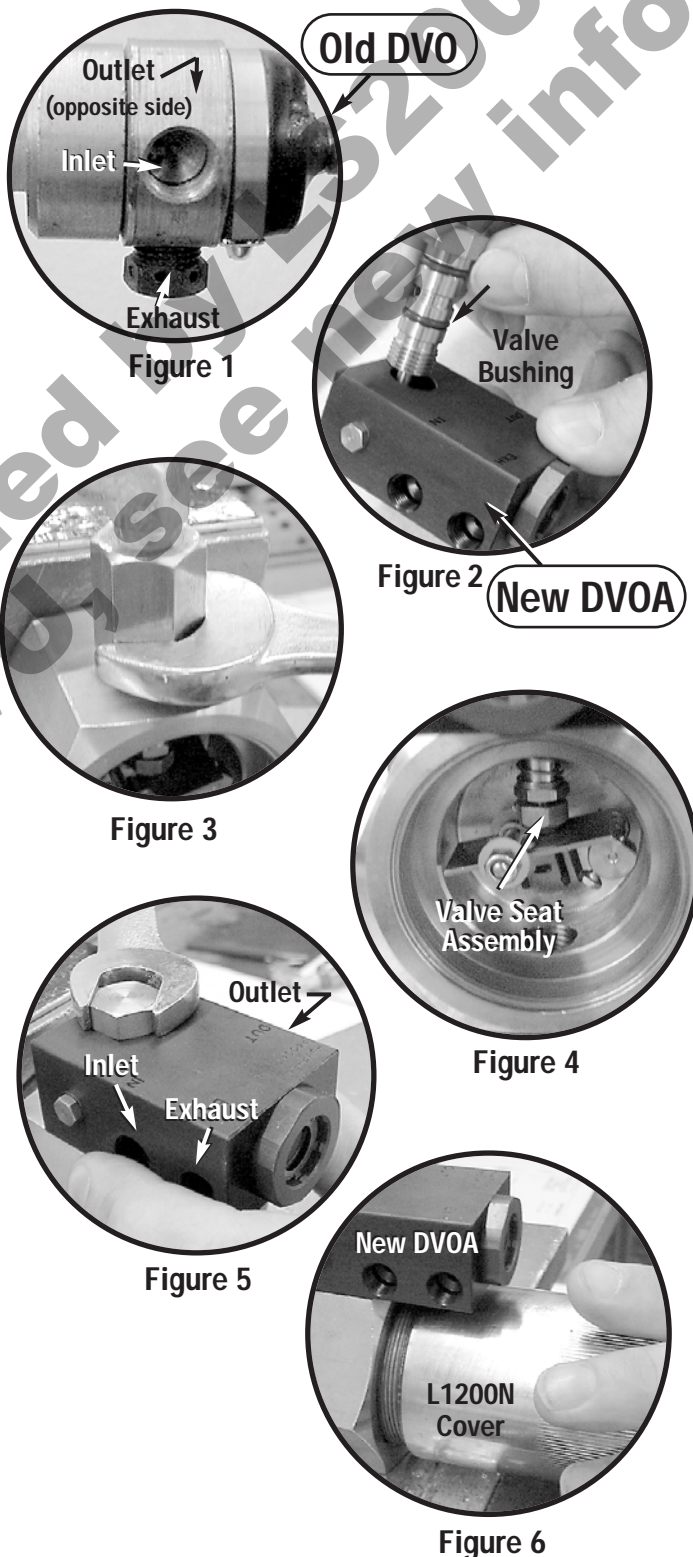

PRESSURE VESSEL INSTALLATION: L1100, L1200, and L1200N

Direct Installation into the Wall of the Pressure Vessel

1. Determine that the float travel is not obstructed by the coupling in the vessel wall, internal baffles, etc.
Do NOT use more than one arm extension P/N 15050395.
2. BE SURE that the float and extension are tight and that the lock washer is in place.
3. Before installing the level switch a suitable pipe thread sealant is recommended. Screw the unit directly into the threaded connection in the wall of the pressure vessel.
4. Be sure that the electrical connection is positioned at the bottom. For L1200N the 1/8 NPT pneumatic connection should be on top (the 1/4 NPT vent connection should be on the bottom). See "Pneumatic models" section for further instructions for the L1200N.
5. Make the electrical wiring connections according to appropriate wiring diagrams for the alarm or shutdown system to be used. The electrical connection is 1/2-14 NPT. Electrical wiring and conduit should be installed by qualified personnel according to the NEC.
6. BE SURE all electrical connections are insulated and the cover is fully installed before reconnecting electrical power.
7. BE SURE all pressure connections are tight before pressurizing the system.

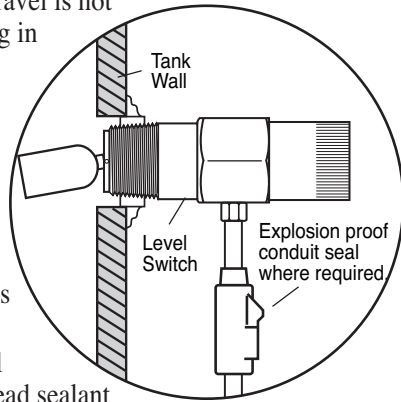

Installation with a Weld Collar

1. The weld collar, P/N 15050375, must be welded into the wall of the pressure vessel according to code standards and good welding practices.
2. Follow above instructions for installation directly into the wall of the pressure vessel.
3. **NOTE: Weld collar 15050375 can be used ONLY with model L1200. It cannot be used with L1200N.**

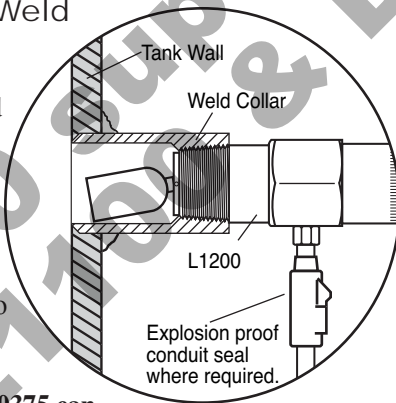

Installation Using External Float Chamber 15051098

CAUTION: USE "NON SPARKING TOOLING".

1. Install the float chamber 15051098 on the outside wall of the pressure vessel using 1 NPT piping. Position the 2 NPT threaded connection at the height where you want the level switch to operate. The 2 NPT threaded connection must be

positioned away from the tank wall.

2. A tee is typically installed at the bottom of the lower 1 inch pipe riser to allow draining of the float chamber for servicing or replacement.

NOTE: A typical installation with Blocking and Bleed valves is shown at right.

3. Install the L1200 or L1200N in the 2 NPT connection of the float chamber. BE SURE float travel is not restricted and that the float is tight onto the float shaft.

4. To complete installation and wiring, follow the instructions for mounting directly into wall of the vessel and for wiring.

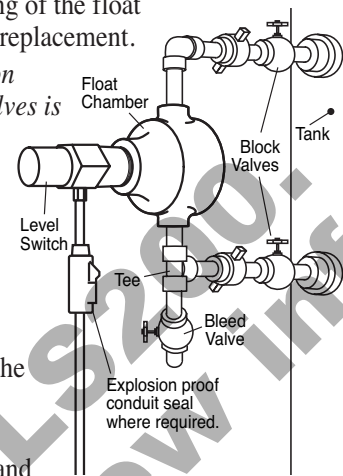

Pneumatic Models

1. All pneumatic models operate on the vent principle. The pneumatic signal source **MUST BE CLEAN AND DRY**. The input pneumatic signal must be regulated between 30 and 70 psi (207-483 kPa) [2.07-4.83 bar].

If produced gas is used as the signal source, it should be taken after gas passes through the final scrubber.

A suitable filter must be positioned before the L1200NDVO to prevent liquids and/or particulates from entering the dump valve operator.

NOTE: Check filter periodically for wear and tear and elements that hamper the flow of the pneumatic signal.

2. All pressure connections must be tight and maintained tight so as not to leak air/gas.
3. Valve seat adjustment can be made if air/gas begins to leak. Care should be taken when adjusting as only slight movement is necessary to stop the leakage; excessive force will bind the

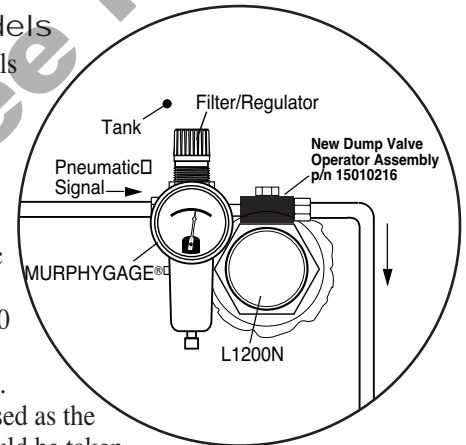

Hex Socket Set Screw
• loosen for adjustment
• tighten after adjustment

Hex Adjustment Nut
• turn left until air seepage stops
• **Caution:** only slight adjustment is needed—too much will lock up mechanism

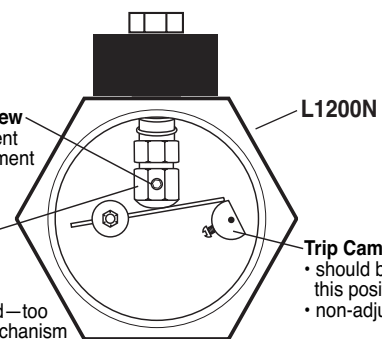

Trip Cam (float down)
• should be in this position
• non-adjustable

TYPICAL INSTALLATION ON GAS COMPRESSORS

Basic Operation

As condensate rises in the scrubber, the float on the L1200NDVOR rises and trips its pneumatic valve. The valve opens allowing pressure to enter the dump valve pilot chamber. Once the pressure enters the pilot chamber it forces the diaphragm and valve stem forward thus opening the valve seat (valve open/closed indicator button pops out) and releasing condensate through the valve stem and out the drain. As the condensate level drops, the L1200NDVOR pneumatic valve closes to shut off the pressure to the dump valve causing it to close.

If for any reason the condensate continues to rise beyond normal dump levels, model L1200 operates the alarm and/or shuts down the equipment.

The L1200NDVOR Filter/Regulator and the MURPHYGAGE® help keep the control pressure clean and dry. They also allow the operator to adjust pressure to recommended levels.

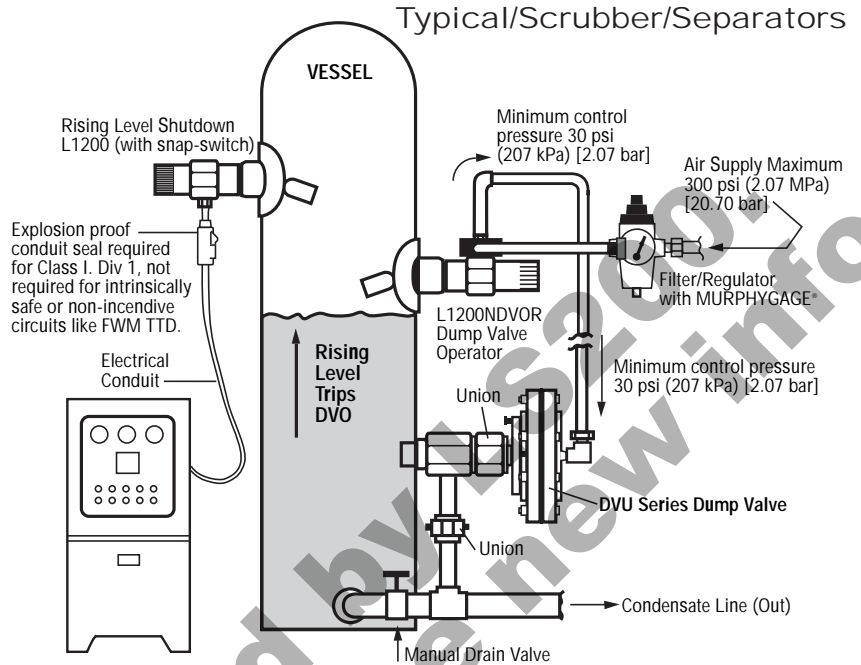

ELECTRICAL INFORMATION

SPDT (Snap Switch)

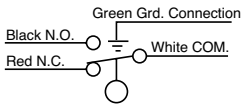

Switch Rating: 5 A @ 125-250- 480 VAC
 1/2 A @ 125 VDC
 1/4 A @ 250 VDC
 2A @ 6-30 VDC Resistive
 1A @ 6-30 VDC Inductive

DPDT (Snap Switch)

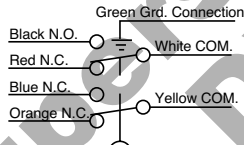

Switch Rating: 10 A @ 125-250 VAC
 1/2 A @ 125 VDC
 1/4 A @ 250 VDC
 10 A @ 6-24 VDC Inductive/Resistive

REPLACEMENT PARTS

Order by part number designation.

L1100/L1200*

- 15000893: BUOYGLAS™ float
- 15000894: Stainless Steel float for L1200
- 15000937: Stainless Steel float for L1100
- 15000124: SPDT snap switch assembly
- 15010213: L1100 counter balance assembly
- 15010214: L1200 counter balance assembly

L1200N

- 15050420: Cam spring return
- 15050421: Cam
- 15000893: BUOYGLAS™ float
- 15000894: Stainless Steel float for L1200N
- 15050453: Valve stem
- 15010189: Counter balance assembly

L1200NDVO and L1200NDVOR

- 55050621: Regulator only
- 05706499: 20BPG-D-75 Pressure MURPHYGAGE®
0-75 psi (517 kPa) [5.17 bar]
- 15010216: DVOA assembly (New rectangular style)
- 15000940: DVO assembly (Old round style)

*To maintain hazardous location listings, all other repairs must be made by the factory.

ACCESSORIES

Order by part number designation.

55050617: DVU150/DVU175 Adapter Bushing

Material: 2-1/2 Hex bar stock C.R.S

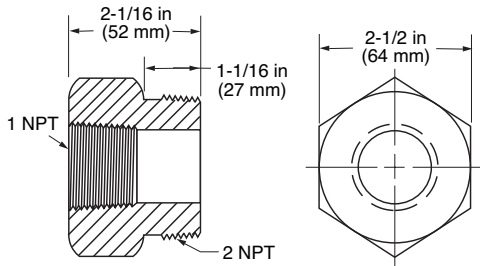

15050375: Weld Collar

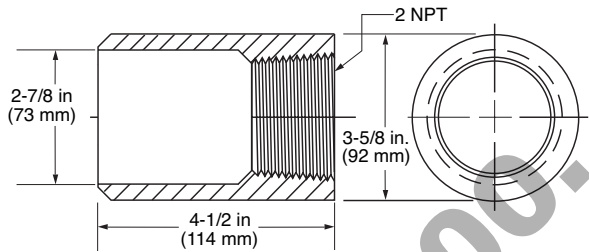

Operating Pressure: 2000 psi (13.8 MPa) [138 bar].
Operating Temperature: 400°F (204°C).

15051098: External Float Chamber

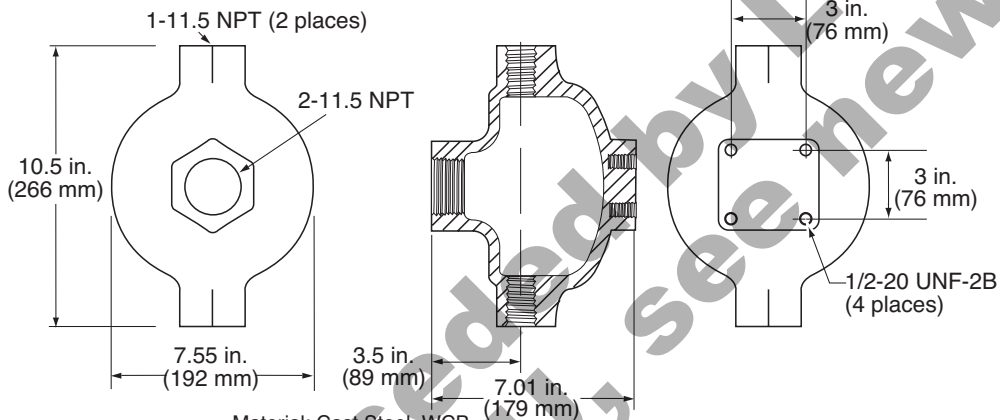

Material: Cast Steel, WCB

Operating Pressure: 2000 psi (13.8 MPa) [138 bar].
Operating Temperature: 400°F (204°C).

15000892: Float Shaft Extension

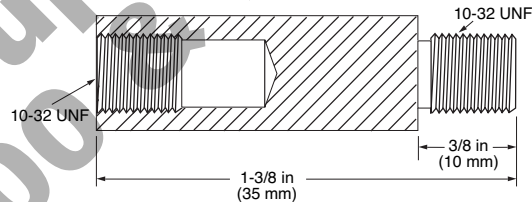

Warranty

A limited warranty on materials and workmanship is given with this FW Murphy product.
A copy of the warranty may be viewed or printed by going to www.fwmurphy.com/support/warranty.htm

MURPHY®

www.fwmurphy.com

918.317.4100 Email: sales@fwmurphy.com

MURPHY, the Murphy logo are registered and/or common law trademarks of Murphy Industries, Inc. This document, including textual matter and illustrations, is copyright protected by Murphy Industries, Inc., with all rights reserved. (c) 2006 Murphy Industries, Inc. Other third party product or trade names referenced herein are the property of their respective owners and are used for identification purposes only.