

LR857 series Oil Level Regulator

ys6362
revision B, 2015-06-25
catalogue section 15



Description

The Murphy LR857 oil level regulator provides automatic maintenance of engine crankcase oil level. The device can be used in a range of engine, generator, compressor or pump applications.

When adjusted to the correct (engine running) oil level, the LR857 will automatically replenish oil as it is used. Regulation is by a float and Thumb-Valve™ mechanism:-

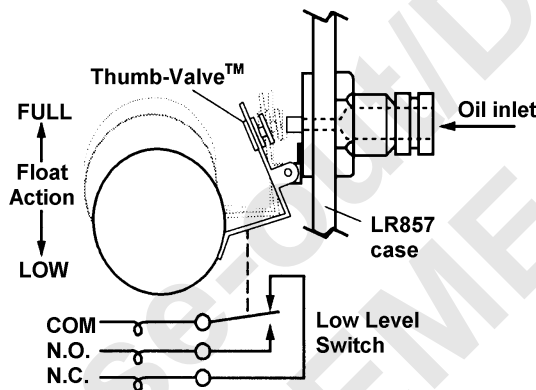

The simple and unique Thumb-Valve™ is non-clogging and provides a positive, leak-free seal. The LR857 float mechanism also has an integral low-level switch that provides alarm and/or equipment shutdown if the oil level falls too low. The float switch has a front facia knob that can be turned to test the alarm/shutdown circuit.

The LR857 is housed in a rugged aluminium case and is available with a range of pipe fitting and mounting options.

Warranty

This Murphy product is supplied with a two year limited warranty on materials and workmanship, details available on request and at www.fwmurphy.co.uk/warranty.

- Automatically maintains engine oil level
- Visible indication of oil level
- Low level alarm / shutdown switch with test facility
- Eliminates over/under fill
- Simple installation

Specification

Process connection:

inlet connection	barbed fitting for 16mm / 5/8" ID hose; inside (female) thread 1/4" NPT
outlet connection	3/8" NPT female thread (optional hose fittings available)

Electrical:-

snap-switch	SPDT volt-free contacts, 5A @ 120 VAC, 2A resistive / 0.75A inductive @ 6 – 36 VDC
-------------	--

Physical:

case	die cast aluminium
lens	polycarbonate
float	brass
fittings and plugs	brass
shipping dimensions	260 x 170 x 170 mm
weight	0.95 Kg (LR857) to 1.2 Kg (LR857-F-U)

Flow rates

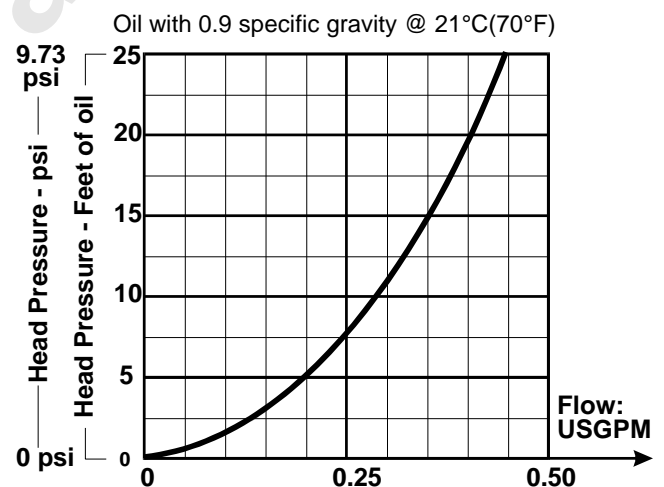

Dimensions

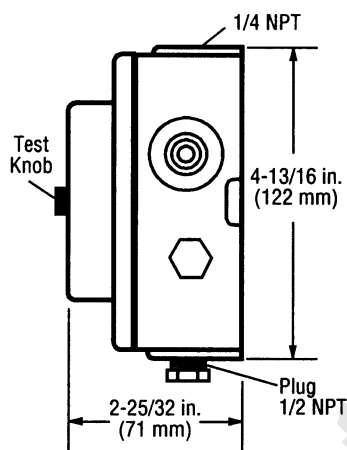
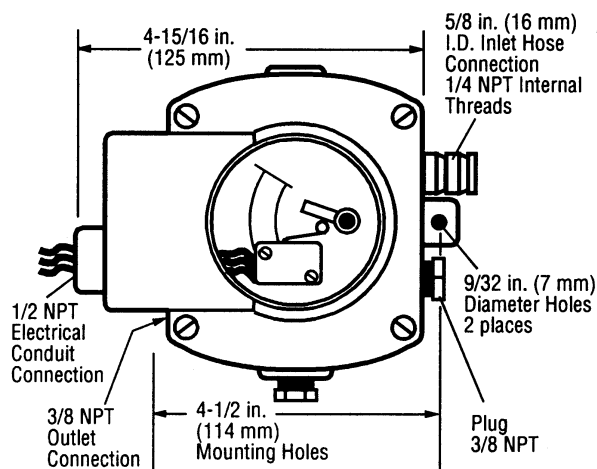

Mounting brackets

Murphy offer two mounting brackets for the LR857. The 15.00.0235 (or "P" option) pipe bracket kit fits a 7/8 inch (22mm) diameter pipe (see typical installation below). The 15.01.0223 (or "U" option) universal flange kit allows various mounting methods.

1500238

Pipe Bracket Kit

Additional Hardware Supplied

- (2) 1/4-20 x 7/8 inch (22 mm) screws
- (2) 1/4-20 x 1 inch (25 mm) screws
- (4) 1/4-20 hex nuts
- (4) 1/4 inch (6 mm) dia. split washer

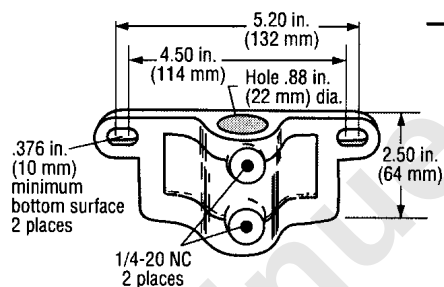

15010224

Universal Flange Kit

Additional Hardware Supplied

- (2) 1/4-20 x 1-1/4 inch (32 mm) bolts
- (4) 1/4 dia. flat washer
- (2) 1/4-20 hex nuts
- (2) 5/16-18 x 1-1/4 inch (32 mm) bolts
- (4) 5/16 dia. flat washer
- (2) 5/16-18 hex nuts

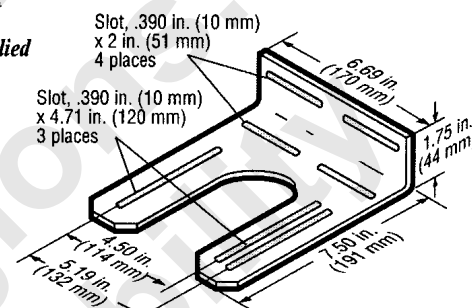

How to order

stock code	Description
<i>Complete units:-</i>	
LR857	Basic model, no extra fittings or mounting bracket
LR857-F	LR857 + fittings kit (15.00.0420 below)
LR857-P	LR857 + pipe bracket (15.00.0238 below)
LR857-U	LR857 + universal bracket (15.01.0224 below)
LR857-F-P	LR857 + fittings kit + pipe bracket
LR857-F-U	LR857 + fittings kit + universal bracket

Spare fittings & mounting bracket kits:-

15.00.0420	Fittings kit: - 1/4" NPT male x 1/4" (6mm) pipe fitting (vent) - 1/4" (6mm) OD copper cane tube (vent) - 3/8" NPT x 1/2" ID barbed hose fitting (outlet)
15.00.0238	Pipe bracket kit, components as above right
15.01.0224	Universal bracket, components as above right

Typical installation

