

SM Series TANKTEND™ Systems Installation and Operation Instructions



Models: SM1, SM1VR, SM2, SM2VR, SM3, SM3VR, SM4, SM4VR

Please read the following information before installing. A visual inspection of this product for damage during shipping is recommended before mounting. It is your responsibility to have a qualified person install this unit and make sure it conforms to NEC and local codes.

GENERAL INFORMATION

WARNING

BEFORE BEGINNING INSTALLATION OF THIS MURPHY PRODUCT

- ✓ Disconnect all electrical power to the machine.
- ✓ Make sure the machine cannot operate during installation.
- ✓ Follow all safety warnings of the machine manufacturer.
- ✓ Read and follow all installation instructions.

The SM Series System can monitor above or below ground, single or multi-tank systems (4 tanks maximum). The SM Series includes BGT1 gage (s) in a wall mounting panel. The SMVR series includes a vapor recovery option that compensates for gas blankets or head pressure caused by vapor recovery storage systems.

The SM includes a push-button actuated electrical pump assembly, that supplies the air to clear sensing lines for current readings. Pump operating voltages available are 120 or 230 VAC (see below).

SM Series Specifications

Panel: Hollow wall mount, cold rolled steel, painted.

Shipping Weight (P100 Pump included):

- SM1: 27 lb. (12.25 kg) approximately.
- SM2: 44 lb. (20 kg) approx.
- SM3: 54 lb. (24.5 kg) approx.
- SM4: 65 lb. (29.5 kg) approx.

Shipping Dimensions for All Models (P100 Pump included):

40 x 9 x 15-3/4 in. (1016 x 229 x 400 mm).

SMPA and SMPA230 Pump Assemblies

Operating Voltage: 120 VAC (SMPA); 230 VAC (SMPA230).

Power Cable: Insulated, 16 AWG (1.5 mm²) x 8 ft. (2.4 m).

Case: Weatherproof enclosure; painted.

Shipping Weight: 10 lbs. (4.53 kg).

Shipping Dimensions: 12 x 12 x 10 in. (305 x 305 x 254 mm).

SMPA and SMPA230 Mounting Dimensions

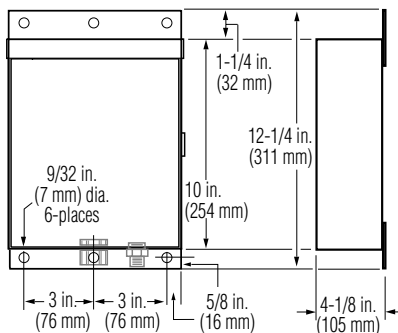

Mounting Dimensions

SM1 / SM1VR (1-Tank Monitoring Systems)

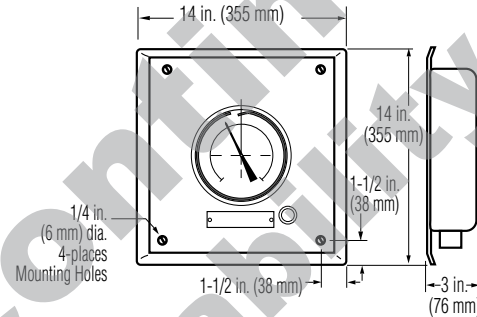

SM2 / SM2VR (2-Tank Monitoring Systems)*

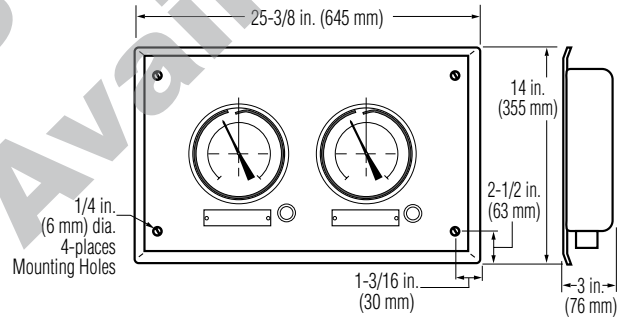

SM3 / SM3VR (3-Tank Monitoring Systems)*

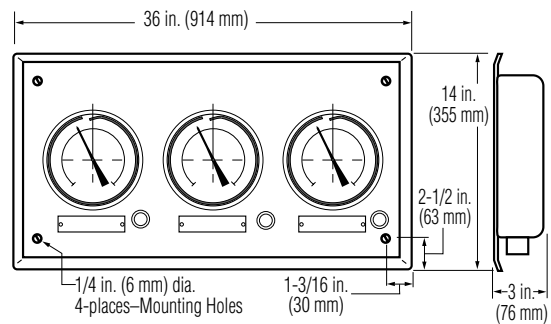

SM4 / SM4VR (4-Tank Monitoring Systems)*

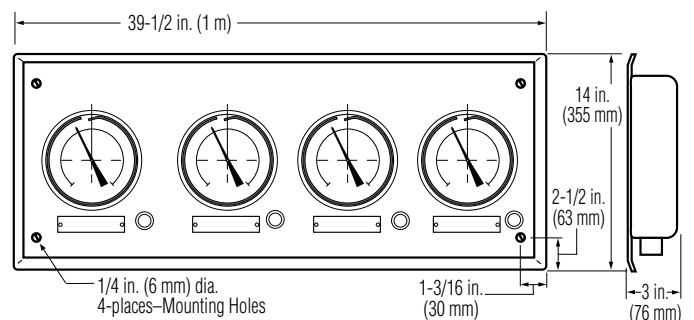

* Mounting dimensions also apply for vertical mounting configurations.

INSTALLATION

WARNING: Installation of the SM and SMVR Series MUST BE made by qualified installer. Hazardous conditions exist with flammable and corrosive products. Extinguish all smoking materials. Risk of explosion, fire and burning can cause serious or fatal injury.

Installing a Tank Plug Kit (all models)

The tank plug kit includes 12 ft. (3.6 m) x 1/4 in. (6 mm) dia. stainless steel tube and fittings. Tank plug is available in 2 NPT or 4 NPT.

1. Locate tank(s) service cover and install a UTKN tank plug kit for each tank. Necessary hardware is available from Murphy, refer to "Service Parts and Accessories" section, on page 4.

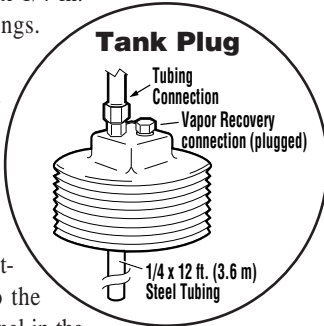

2. Route a tubing line (1/4 in. [6 mm] outside dimension) from the tank top to the panel location. If applicable, cut a channel in the driveway surface to route the tubing. The use of rigid conduit is recommended especially when routing the tubing line under a driveway surface. Refer to Fig. 1, at right.

3. Before inserting the 1/4 in. (6 mm) dia. stainless steel tubing (probe) through tank plug fitting, make sure tubing can reach bottom and also will allow extra tubing for adjustments. Now lower the tubing until it touches the bottom of the tank, do this as follows (refer to Detail A, at right):

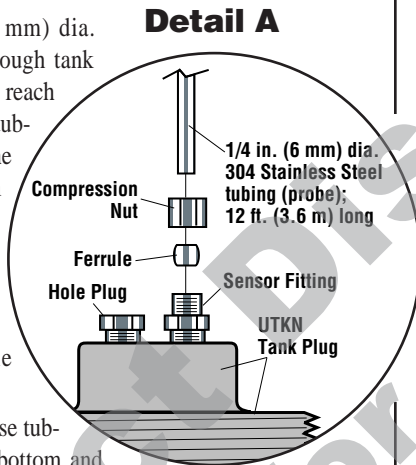

- A. First, loosen ferrule and ferrule fitting nut.
- B. Insert the tubing through the ferrule nut and fitting.
- C. Mark tubing at top of fitting—raise tubing exactly 3 in. (76 mm) off bottom and finger tighten ferrule and compression nut.

CAUTION: Excessive tightening of ferrule fittings will prohibit re-adjustment if necessary.

- D. Cut excess stainless steel tubing allowing 1/2 in. (13 mm) extension above the compression nut.

4. Connect tubing line to tank probe as shown (refer to Detail B, at right).

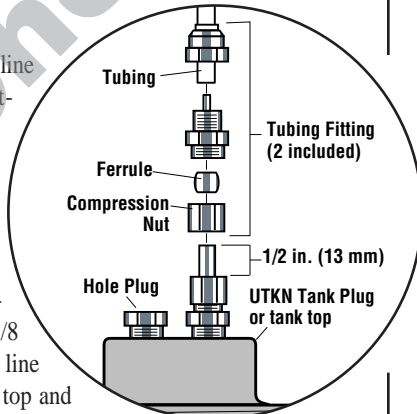

5. Now connect other end of tubing line to the SM/SMVR gage panel fitting. Tubing should be continuous length without splices.

6. For SMVR models, connect a second line from the tank top (if using UTKN kit, remove Hole Plug and install second sensor fitting and line) to the SMVR gage 1/8 NPTF fitting line. Second sensing line is to be installed through the tank top and into the tank, but keep the tip of the line above product level (refer to Fig. 2, at right and Fig. 3, next page).

7. Securely tighten all fittings; all connections must be air tight.

Fig. 1 SM Series Typical Installation

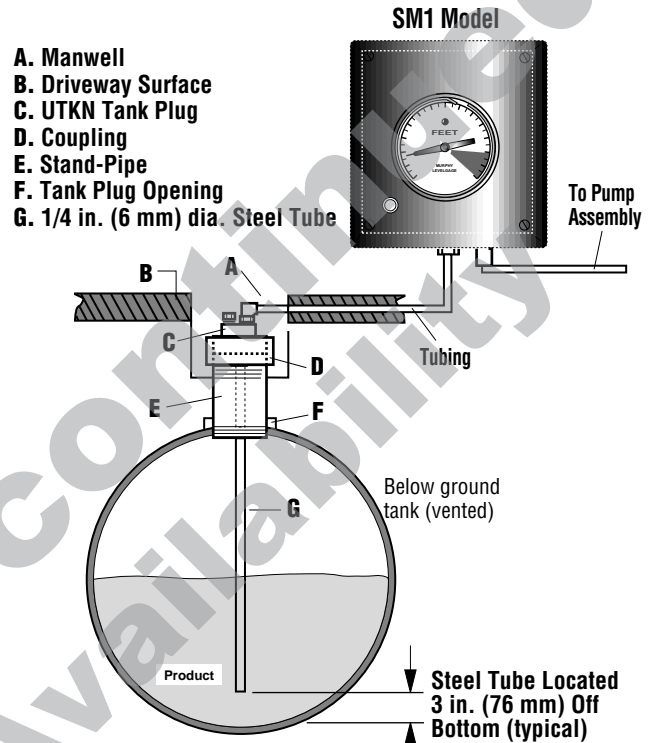
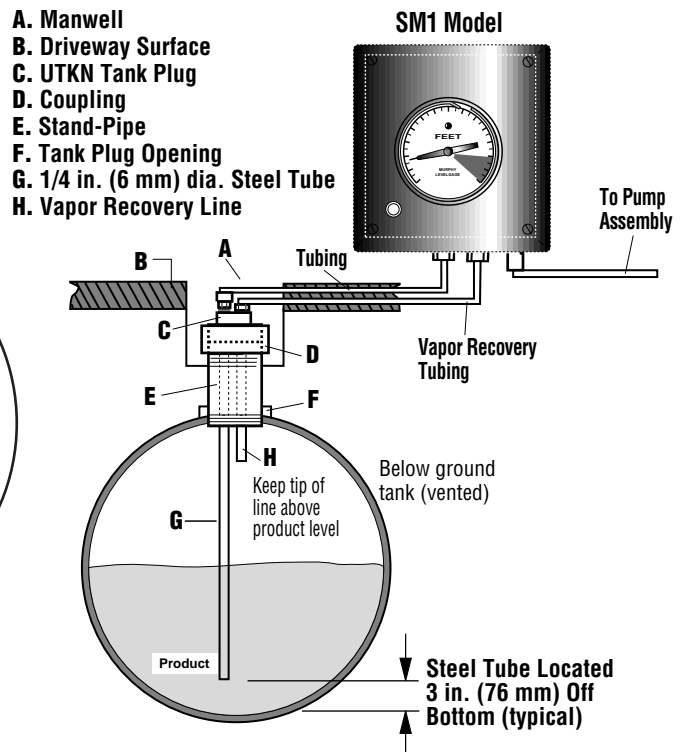

Fig. 2 SMVR Series (Vapor Recovery Systems) typical Installation



Installing the CKBO Check Valve

The optional CKBO check valve is designed to prevent product from backing up into the gage(s). We recommend installing the CKBO valve at top of the tank plug as follows (refer to **Detail C**):

1. Determine a location for the valve. Use of sealant on all fitting threads is strongly suggested.
2. Attach CKBO to the tank plug using wrench on valve flats. See markings on the valve body for positioning.
3. Attach tubing to CKBO as shown. Securely tighten all fittings. All connections must be air tight.

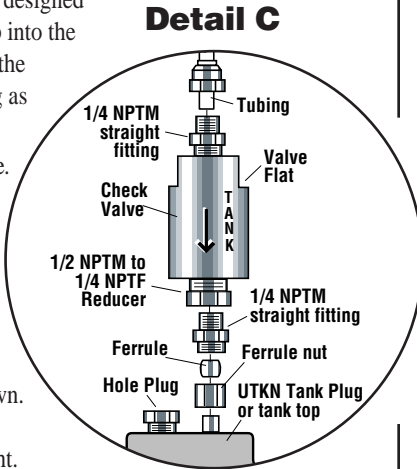

Installing the SMPA/SMPA230 Pump Assembly

The pump assembly should be installed near the SM or SMVR panel. Connect the pump as follows (refer to **Fig. 3 and 4** also see **Detail D**):

1. Before connecting the tubing from the SM or SMVR panel to the pump assembly, make sure the tubing reaches the pump assembly sensor fitting.
2. Connect the end of the tubing to the sensor fitting as shown at right (Detail D). Tubing should be continuous length without splices.
3. The pump assembly includes a power cable, 16 AWG (1.5 mm²), 8 ft. (2.4 m) long. Connect the cable to 120 VAC or 230 VAC power source.

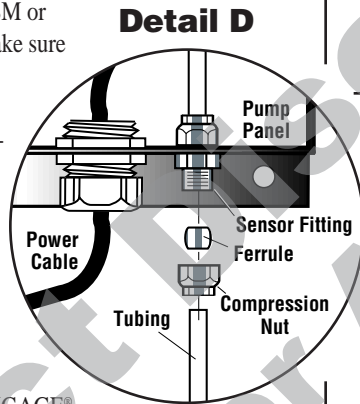

The pump assembly has a pressure SWICHGAGE® with low and high pressure set points. When the gage pointer reaches the low pressure set point, the pump starts to build up purge pressure. When the pointer reaches the high set point, sufficient volume is reached stopping the pump. The set points are factory pre-set for your convenience.

Resetting the Pointer

CAUTION: SM and SMVR models are precalibrated in feet of static pressure above gage connection. Pointer **MUST** be reset to zero.

After the SM/SMVR complete system has been connected, reset the pointer for proper level indication, proceed as follows (see **Fig. 5** and **Detail E**):

1. Determine actual product level by any reliable means and record this value.
2. Very carefully remove the retaining ring guarding against its spring-action, it can cause injuries. Remove the lens also.
3. Carefully hold the pointer, as shown at right, making sure not to bend it.
4. With a small screwdriver, turn the setting screw to corresponding stick reading value recorded in step 1. Clockwise to raise the pointer — counter clockwise to lower the pointer.
5. Replace the lens and snap ring.

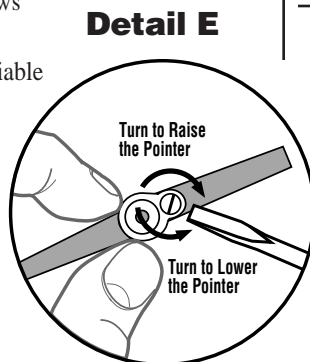

Fig. 3 SM Panel Tubing Configuration (SM2 Model shown)

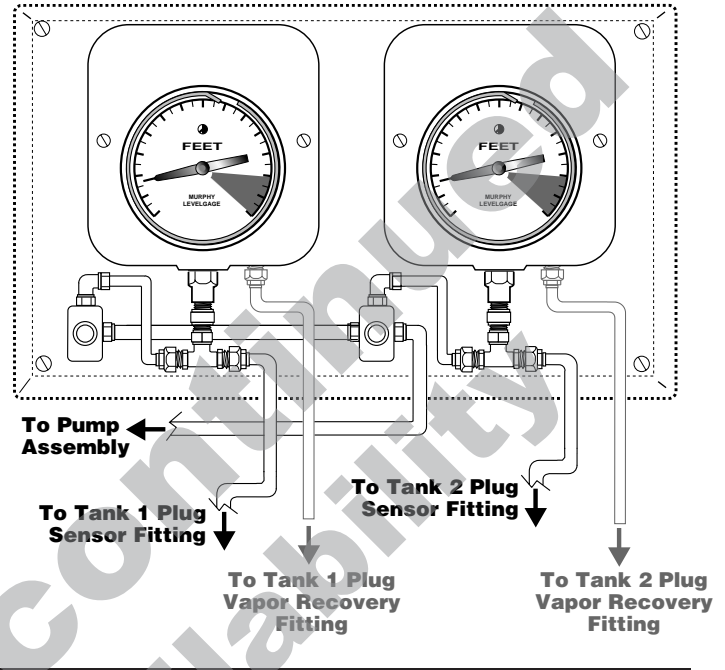

Fig. 4 Pump Assembly

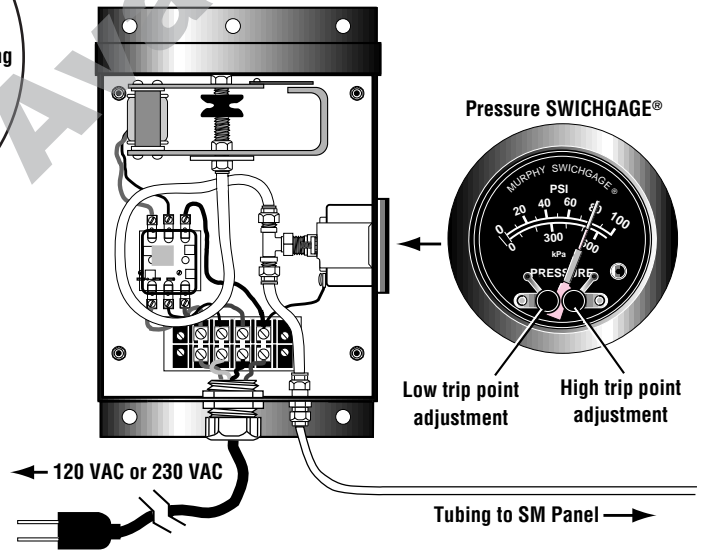
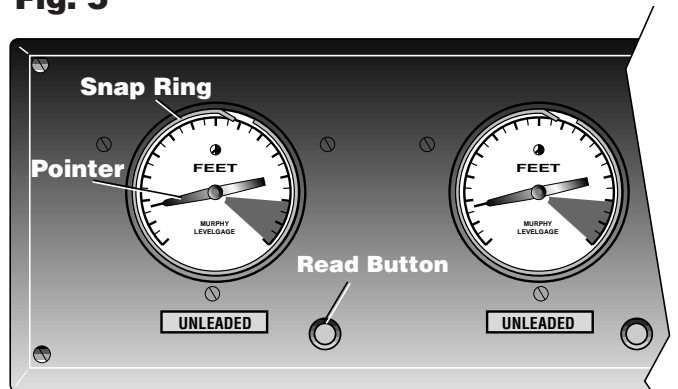

Fig. 5



Operation Sequence



IMPORTANT: Make sure SM Series system is completely installed and operative. Check that all connections are air tight.

1. Make sure that the pump assembly is connected to a power source, either 120 VAC or 230 VAC according to the pump model used.
2. Depress the read button, located next to the gage(s) and hold until the gage pointer stops traveling across the scale. See Fig. 6, at right.
3. When pointer stops release the read button to allow pointer to settle.
4. The value observed in the dial of the gage, is the level of the tank.
5. Perform this operation as necessary for each tank to be checked.

Fig. 6

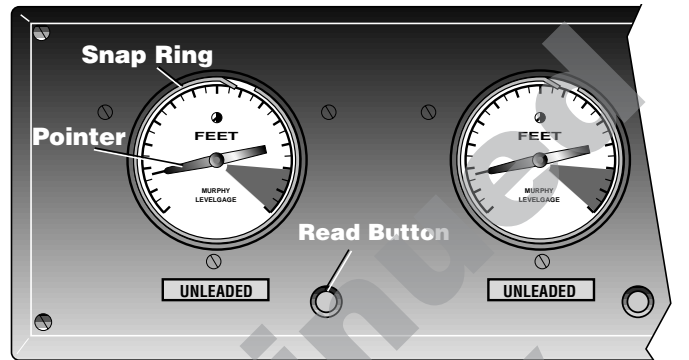

Service Parts and Accessories

UTKN2:	2 NPTM tank plug kit (includes 12 ft. [3.66 m] of stainless steel tubing/probe and fittings).
UTKN2LT:	2 NPTM tank plug less tubing (includes fittings).
UTKN4:	4 NPTM tank plug kit (includes 12 ft. [3.66 m] of stainless steel tubing/probe and fittings).
UTKN4LT:	4 NPTM tank plug less tubing (includes fittings).
UTKN4VR:	4 NPTM tank kit for vapor recovery (tubing and fittings included).
UTKN4VRLT:	4 NPTM tank plug for vapor recovery– less tubing (includes fittings).
SMPA:	Pump assembly for 120 VAC.
SMPA230:	Pump assembly for 230 VAC.
05090051:	Pressure SWICHGAGE® instrument with low and high pressure limit contacts, 15 psi scale.
CKBO:	Check Valve assembly–prevents product from backing up into gage.
85-01-0405:	1/2 NPTM x 1/4 NPTF reducing bushing–for CKBO valve mounting.
85-01-0402:	1/4 in. (6 mm) dia. 316 stainless steel tubing/ft. (probe).
85-01-0403:	1/4 in. (6 mm) dia. poly tubing/ft. (sensing line).
86-03-0405:	1/4 x 1/4 male hex nipple kit–for connecting tubing line to tank top.
85-03-0407:	1/4 x 1/4 male hex fitting kit–for connecting tubing or probe line to the tank top.

Warranty

A two year limited warranty on materials and workmanship is provided with this Murphy product.

Details are available on request and are packed with each unit.

In order to consistently bring you the highest quality, full featured products, we reserve the right to change our specifications and designs at any time.



■ **Frank W. Murphy Manufacturer**
 P.O. Box 470248; Tulsa, Oklahoma 74147; USA
 tel. (918) 627-3550 fax (918) 664-6146
 e-mail fwmurphy@ionet.net

■ **Frank W. Murphy Southern Division**
 P.O. Box 1819; Rosenberg, Texas 77471; USA
 tel. (281) 342-0297 fax (281) 341-6006
 e-mail murphysd@intertex.net

■ **Frank W. Murphy, Ltd.**
 Church Rd.; Laverstock, Salisbury SP1 1QZ; U.K.
 tel. +44 1722 410055 fax +44 1722 410088 tlx 477088
 e-mail sales@fwmurphy.co.uk

■ **Frank W. Murphy Pte., Ltd.**
 26 Siglap Drive; Republic of Singapore 456153
 tel. +65 241-3166 fax +65 241-8382
 e-mail fwmsales@fwmurphy.com.sg

■ **Murphek Pty., Ltd.**
 1620 Hume Highway; Campbellfield, Vic 3061; Australia
 tel. +61 3 9358-5555 fax +61 3 9358-5558

■ **Murphy de México, S.A. de C.V.**
 Blvd. Antonio Rocha Cordero 300, Fracción del Aguaje
 San Luis Potosí, S.L.P.; México 78384
 tel. +52-48-206264 fax +52-48-206336
 e-mail murmexsl@sanluis.podernet.com.mx

■ **Murphy Switch of California**
 P.O. Box 900788; Palmdale, California 93590; USA
 tel. (805) 272-4700 fax (805) 947-7570
 e-mail sales@murphyswitch.com

■ **Frank W. Murphy France**
 tel. +33 1 30 762626 fax +33 1 30 763989