

# Dump Valves



## DV Series



- For Separators/Scrubbers to 2000 psi (13.7 MPa) [137 bar] Vessel Pressure
- Unique Positive-Seal, Field-Replaceable Piston Seal and Body Seat Assembly
- Operates on 30–70 psi (207–483 kPa) [2.07–4.83 bar] Control Pressure
- Built-In Valve Open/Closed Pop-Up Indicator Button
- Compatible with Murphy Level Controls

### Description

The DV850, DV875, and DV2100 are pneumatically controlled dump valves. They open and close automatically by pneumatic control from a Murphy L1200NDVOR or similar level controller and dump valve operator. Diaphragm actuated, the DV series dump valves operate at 30–70 psi (207–483 kPa) [2.07–4.83 bar] and up to 2000 psi (13.7 MPa) [137 bar] vessel pressure. See “Operating Pressures” chart.

Murphy offers stainless steel versions of the DV850, DV875, and DV2100 Series.

**NOTE:** All stainless steel versions carry Canadian Registration Number OC1476.2.

### Operating Pressures

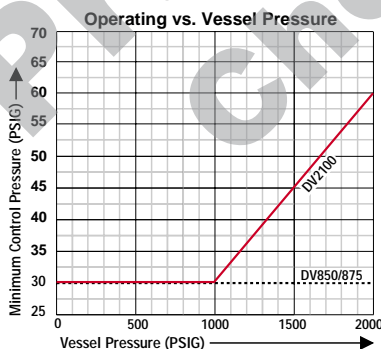

### Application

Primarily designed for compressor scrubbers, these valves can be used to dump any liquids compatible with the valve's specifications.

### Specifications

#### Operating Temperature:

-30 to +300°F (-34.4 to +149°C)

#### Valve Operating Pressure:

30–70 psi (207–483 kPa) [2.07–4.83 bar]

#### Maximum Process Pressure:

2000 psi (13.7 MPa) [137 bar]

#### Stem Seal: Carbon/Graphite Filled PTFE

**Upper Case Coating:** Electroless Nickel Plated on 12L14 Carbon Steel.

#### Body Material: DV850, DV875, and DV2100:

Electroless Nickel Plated 12L14 Carbon Steel  
DV850SS, DV875SS, and DV2100SS: ANSI 316 (UNS31600) Stainless Steel

#### Wetted Parts: Body: 12L14 Carbon Steel.

Optional ANSI 316 stainless steel.

Shaft/Stem: ANSI 316 stainless steel.

Guidebushing: ANSI 316 stainless steel.

Body Seat: ANSI 316 stainless steel.

Piston Seal: ANSI 316 stainless steel.

### Dimensions

	DV850/SS	DV875/SS	DV2100/SS
A	6-3/4 (171)	6-3/4 (171)	6-3/4 (171)
B	7-9/64 (181)	7-9/64 (181)	7-59/64 (201)
C	3-9/32 (83)	3-9/32 (83)	3-63/64 (101)
D	2-19/64 (58)	2-19/64 (58)	2-5/32 (55)
E	1 NPT	1 NPT	2 NPT
F	1/2 NPT	3/4 NPT	1 NPT
G	1/8 NPT	1/8 NPT	1/8 NPT

**NOTE:** Dimensions are in inches and (millimeters)

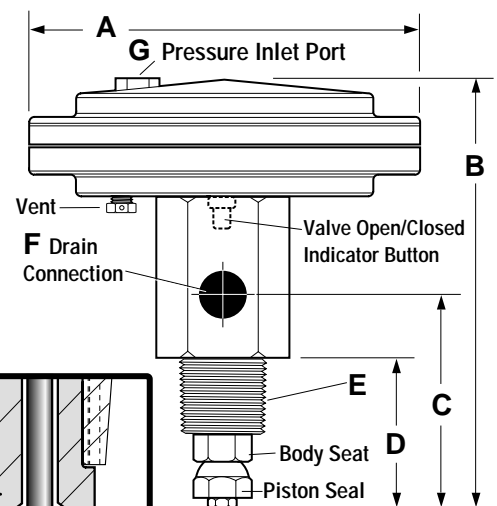

### Positive-Seal Detail

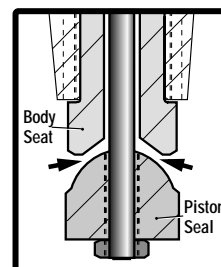

## Dump Valve Operation ▶

As condensate rises in the scrubber, the float on the Murphy L1200NDVOR rises and trips its pneumatic valve. The valve opens allowing pressure to enter the dump valve pilot chamber. Once the pressure enters the pilot chamber it forces the diaphragm and valve stem forward thus opening the valve seat and releasing condensate through the valve stem and out the drain (a pop up button indicates valve open/closed). As the condensate level drops, the L1200NDVOR pneumatic valve closes to shut off the pressure to the dump valve, allowing it to close.

If for any reason the condensate continues to rise beyond normal dump levels, model L1200 High Level Shutdown Switch operates the alarm and/or shuts down the equipment.

The MURPHYGAGE® and Filter/Regulator on the L1200NDVOR help keep the control pressure clean, dry, and at proper pressure levels for system activation.

**NOTE: Always use clean, dry, instrument quality gas.**

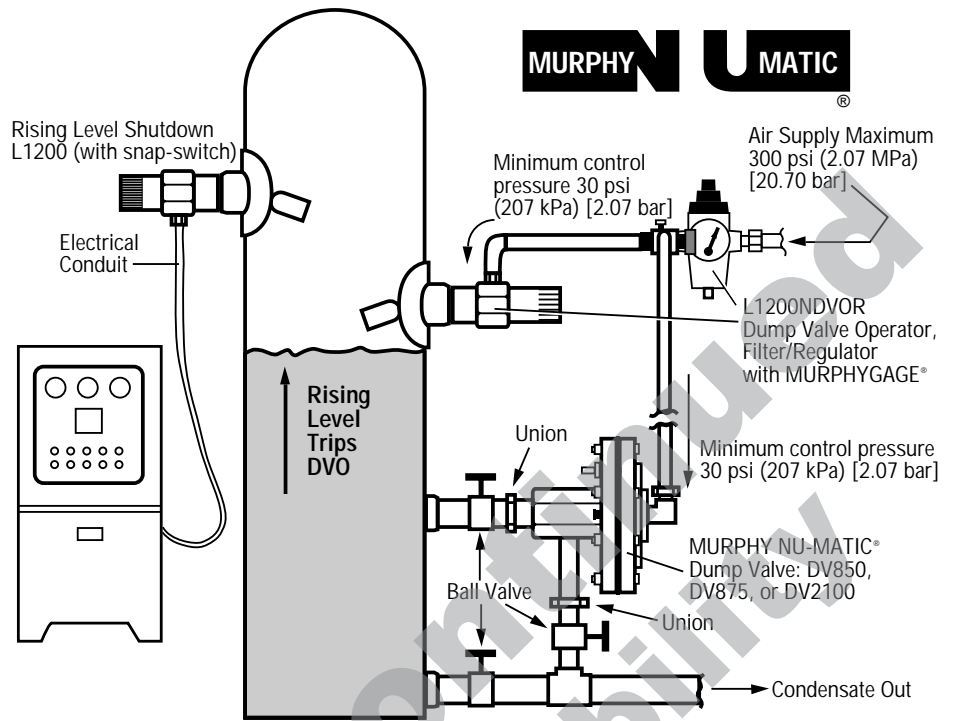

## SLS99 MURPHYMATIC® Scrubber Systems

Patent Pending



Patent 3970099

Patent Pending

Patent 3970099

A complete MURPHYMATIC® system for automatic level control of condensate in scrubbers, shown above, is available as a complete package from Murphy.

### The SLS99A Scrubber System includes:

- (1) DV850 Dump Valve\*
- (1) L1200NDVOR Dump Valve Operator which includes filter/regulator and MURPHYGAGE®
- (1) L1200 High Level Shutdown Switch

\*The dump valve for the SLS99B is DV2100.  
The dump valve for the SLS99C is DV875.

**For more information contact your nearest Murphy sales representative or distributor.**

## How to Order

Specify model number:

- DV850:** 1 NPT Process Connection
- DV850SS†\*:** 1 NPT Process Connection
- DV875:** 1 NPT Process Connection
- DV875SS†\*:** 1 NPT Process Connection
- DV2100:** 2 NPT Process Connection
- DV2100SS†\*:** 2 NPT Process Connection

†AISI 316 Stainless Steel body.

\*Stainless steel models carry Canadian Registration Number OC1476.2.

## Shipping Dimensions

### Shipping Weights

DV850 and DV875: 9 lbs (4 kg).

DV2100: 13 lbs (6 kg).

### Shipping Dimensions (all)

7 x 7 x 11 in. (178 x 178 x 279 mm).

## Replacement Parts

- 55000219 :** Diaphragm Assembly (all models)
- 55000224 :** Seat Kit (piston seal & body seat) for DV850, DV875, DV850SS, DV875SS
- 55000225 :** Seat Kit (piston seal & body seat) for DV2100

### Optional Adapter Bushing

- 55050617 :** 2 NPT to 1 NPT

## Warranty

A two-year limited warranty on materials and workmanship is given with this Murphy product. Details are available on request and are packed with each unit.

*In order to consistently bring you the highest quality, full featured products, we reserve the right to change our specifications and designs at any time.*

**FRANK W. MURPHY MANUFACTURER** P.O. Box 470248; Tulsa, Oklahoma 74147; USA tel. (918) 627-3550 fax (918) 664-6146 e-mail sales@fwmurphy.com http://www.fwmurphy.com



USA-ISO 9001 FM 28221  
UK-ISO 9002 FM 29422

**FRANK W. MURPHY MFR. CONTROL SYSTEMS & SERVICES**  
P.O. Box 1819; Rosenberg, Texas 77471; USA  
tel. (281) 342-0297 fax (281) 341-6006  
e-mail sales@fwmurphy.com

**FRANK W. MURPHY, LTD.**  
Church Rd.; Laverstock, Salisbury SP1 1QZ; U.K.  
tel. +44 1722 410055 fax +44 1722 410088  
e-mail sales@fwmurphy.co.uk  
http://www.fwmurphy.co.uk

**FRANK W. MURPHY FRANCE**  
tel. +33 1 30 762626 fax +33 1 30 763989

**MURPHY DE MEXICO, S.A. DE C.V.**  
Blvd. Antonio Rocha Cordero 300, Fracción del Aguaje  
San Luis Potosí, S.L.P.; México 78384  
tel. +52-48-206264 fax +52-48-206336  
e-mail ventas@murphymex.com.mx

**FRANK W. MURPHY PTE., LTD.**  
No. 2 Tuas South Street 2,  
Sprintec Bldg., #02-01/02  
Singapore 638042  
tel. +65 863-1398 fax +65 863-0208  
e-mail fwmsales@fwmurphy.com.sg

**MURPHY SWITCH OF CALIFORNIA**  
41343 12th Street West  
Palmdale, California 93551-1442; USA  
tel. (661) 272-4700 fax (661) 947-7570  
e-mail sales@murphyswitch.com  
http://www.murphyswitch.com

**MACQUARRIE CORPORATION**  
1620 Hume Highway;  
Campbellfield, Vic 3061; Australia  
tel. +61 3 9358-5555 fax +61 3 9358-5558  
e-mail murphy@macquarrie.com.au