

4-1/2 in. (114 mm) Dial Pressure SWICHGAGE® With Built-In, Snap-Acting SPDT Switches

45PE-96002B
Revised 12-00
Catalog Section 05
(00-02-0771)

FWMurphy

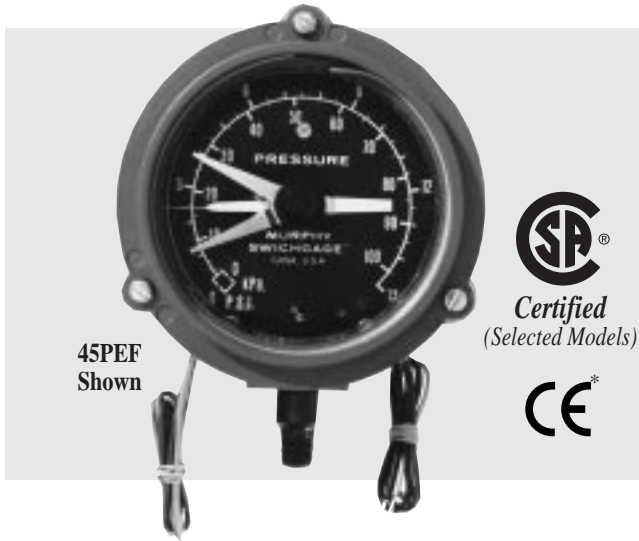

45PEF
Shown

45PE Series

- Combination Indicating Gage and Critical Pressure SPDT Snap-Acting Switches
- High and Low Pressure Trip Point Indicators Are Visible and Field-Adjustable
- Panel and Surface Mount Versions

*Products covered by this bulletin comply with EMC Council directive 89/336/EEC regarding electromagnetic compatibility except as noted.

Description

The 4-1/2 in. (114 mm) dial size SWICHGAGE® is a mechanical gage for pressure indication. It includes 2 adjustable SPDT switches. These snap-acting switches can be used for start and stop, to trip alarms and to shut down equipment.

Ranges are available from 30" vac (-100 kPa) [-1 bar] thru 20,000 psi (138 MPa) [1379 bar].

Basic Operation

This highly reliable gage features a bourdon tube sensing mechanism. Pressure against the bourdon tube translates into a mechanical gage reading.

The gage pointer acts as a pressure indicator. The pointer movement is stopped when it meets the trip point indicator. The bourdon tube continues to travel slightly and the snap-switch trips.

Applications

Murphy 45PE Series models are widely used in electric motor applications due to their 250 VAC pilot duty rating. These models can also be used to monitor gas compressor pressure, pumping applications and industrial process applications.

Specifications

Dial: White on black, dual scale, psi and kPa standard, 4-1/2 in. (114 mm) diameter.

Case: Die cast aluminum, surface or panel mount.

Overrange: Do not exceed 10% above full range.

Process Connection: 1/4 NPT thru 1000 psi; 1/2 NPT 1500 - 20,000 psi. Back connection is optional.

Sensing Element: Select from bronze or 316 stainless steel bourdon tube.

Gage Accuracy: ±2% for first and last quarters of scale; the middle half is ±1%.

Pressure Relief Disc: Located in rear of case (except explosion-proof models).

Snap-Acting Switches:
2-SPDT; 2 A @ 250 VAC.

Dry Relay Contact ("BP" Models):
10 A @ 28 VDC or 10 A @ 120 VAC.

Wire Connections:
Surface mount: 1/2 NPT conduit/ terminal block.
Panel mount: Wire leads, 18 AWG (1.0 mm²) x 9 in. (229 mm) long.

"OS" models: 1/2 NPT conduit and wire leads, 18 AWG (1.0 mm²) x 9 in. (229 mm) long.

Item Weight: 5 lbs 6 oz (2.4 kg) approximately.
Explosion-proof models: 21 lb. (9.5 kg) approx.

Item Dimensions: 10 x 9 x 6 in. (254 x 229 x 152 mm) approximately.

Explosion-proof models: 12 x 12 x 9 in (305 x 305 x 229 mm) approximately.

Basic Models

45PE Series SWICHGAGE®
Surface mount (square case) version.

45PEF Series SWICHGAGE®
Panel mount (round case) version.

45PEBP Latching Control Relay Series
These SWICHGAGE® models feature a latching control relay for automatic ON/OFF control. The 45PEBP are designed to start and stop electric motor driven equipment.

NOTE: 45PEBP series models are NOT certified by CSA or covered by the CE mark.

Dimensions

Surface Mount Models†

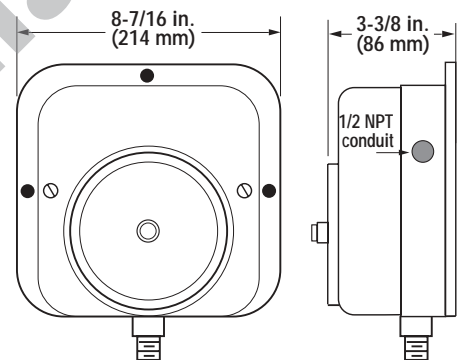

Panel Mount Models

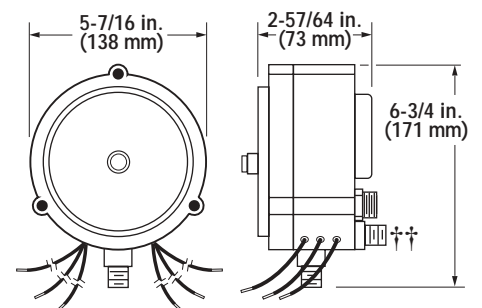

† 45PEE and 45PEBPE models feature square case but altered to fit round panel mounting.

†† Optional back connection.

Warranty

A two-year limited warranty on materials and workmanship is given with this Murphy product. Details are available on request and are packed with each unit.



How to Order

Specify model number. **NOTE:** No designator is required for **Standard** configurations.
List options in alphabetical order (A to Z). Place a dash (-) between each option. See example below.

45PEBP - 4 - S - 100 - EX

Base Model

45PE **45PEE**
45PEF **45PEBPE**
45PEBP

BP Voltage (This feature is NOT cover by CSA or the CE mark)

Blank= 120 VAC
2 = 12 VDC
3 = 24 VAC
4 = 24 VDC

Bourdon Tube/Socket

A = Bronze/Brass (/std. <=1,000 psi)
R = Stainless Steel/Steel (std. >= 1,500 psi)
S = Stainless Steel/Stainless Steel
P = K Monel/Monel 400

Options (NOTE: Not all options available for every model.)

BC = Back Connected Bourdon Tube (is not CSA certified)
CC = Conduit Connection (is not CSA certified)
ES = Environmentally Sealed, 45PEF only (is not CSA certified)
EX = Explosion-proof (hazardous areas certified up to 5000 psig)
EL = (EXLC) Explosion-Proof Less Case
LC = Less Case (is not CSA certified)
OS = Oil Sealed, 45PEF only (is not CSA certified)
P4 = (PT147) PT147 pressure transmitter w/5 ft. capillary*
P4L = PT147 Less Pulsation Dampener*
**For capillary greater than 5 ft., specify in 5 ft. increments following designator, example: P415*
P6 = (PT167) PT167 pressure transmitter direct mount
P6S = (PT167SS) PT167 stainless steel

Dials: Dials are dual scale psi and kPa/MPa. Single scale and custom dials available.

CSA Certified Models: 45PE Series models with pressure range thru 5000 psig (34.4 MPa) [344 bar] are CSA certified for Non-Hazardous locations, except options BC, CC, ES, LC and OS. Explosion-proof "EX" models with pressure range thru 5000 psig (34.4 MPa) [344 bar] are CSA certified for Hazardous locations. 45PEBP models are not CSA certified.

Range

Code	Vacuum/psi	kPa/MPa	bar
30HV60H	30" Hg/Vac - 60" Hg/Press.	-101 kPa-203 kPa	-1.01-2.03
30V	30" vac - 0 psi	-101 kPa - 0 kPa	-1.01 - 0
30V15	30" vac - 15 psi	-101 kPa - 103 kPa	-1.01 - 1.03
30V30	30" vac - 30 ps	-101 kPa - 207 kPa	-1.01 - 2.07
30V100	30" vac - 100 psi	-101 kPa - 689 kPa	-1.01 - 6.89
30V200	30" vac - 200 psi	-101 kPa - 1.38 MPa	-1.01 - 13.79
30V300	30" vac - 300 psi	-101 kPa - 2.03 MPa	-1.01 - 20.68
15	15 psi	0 - 103 kPa	0 - 1.03
30	0 - 30 psi	0 - 207 kPa	0 - 2.06
60	0 - 60 psi	0 - 414 kPa	0 - 4.13
100	0 - 100 psi	0 - 689 kPa	0 - 6.89
160	0 - 160 psi	0 - 1.10 MPa	0 - 11.03
200	0 - 200 psi	0 - 1.38 MPa	0 - 13.78
300	0 - 300 psi	0 - 2.07 MPa	0 - 20.68
400	0 - 400 psi	0 - 2.76 MPa	0 - 27.57
600	0 - 600 psi	0 - 4.14 MPa	0 - 41.36
1000	0 - 1000 psi	0 - 6.89 MPa	0 - 68.95
1500	0 - 1500 psi	0 - 10.34 MPa	0 - 103.42
2000	0 - 2000 psi	0 - 13.79 MPa	0 - 137.89
3000	0 - 3000 psi	0 - 20.68 MPa	0 - 206.84
5000	0 - 5000 psi	0 - 34.48 MPa	0 - 344.73
10000	0 - 10,000 psi	0 - 68.95 MPa	0 - 689.47
20000	0 - 20,000 psi	0 - 137.90 MPa	0 - 1378.94

45PE Series Typical Wiring Diagram

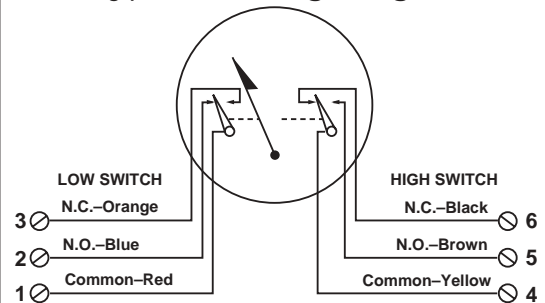

Contact Rating: 2-SPDT snap-switches (one for high and low pressure); 2 A @ 250 VAC

NOTE: Diagram shows the pointer in the at rest (shelf) position.



FWMurphy

P.O. Box 470248
Tulsa, Oklahoma 74147 USA
(918) 317-4100
fax (918) 317-4266
e-mail sales@fwmurphy.com
www.fwmurphy.com

CONTROL SYSTEMS & SERVICES DIVISION
P.O. Box 1819; Rosenberg, Texas 77471; USA
(281) 342-0297 fax (281) 341-6006
e-mail sales@fwmurphy.com

MURPHY DE MEXICO, S.A. DE C.V.
Blvd. Antonio Rocha Cordero 300, Fracción del Aguaje
San Luis Potosí, S.L.P.; México 78384
+52-444-8206264 fax +52-444-8206336
e-mail ventas@murphymex.com.mx
www.murphymex.com.mx

FRANK W. MURPHY, LTD.
Church Rd.; Laverstock, Salisbury SP1 1QZ; U.K.
+44 1722 410055 fax +44 1722 410088
e-mail sales@fwmurphy.co.uk
www.fwmurphy.co.uk

MURPHY SWITCH OF CALIFORNIA
41343 12th Street West
Palmdale, California 93551-1442; USA
(661) 272-4700 fax (661) 947-7570
e-mail sales@murphyswitch.com
www.murphyswitch.com

MACQUARRIE CORPORATION
1620 Hume Highway
Campbellfield, Vic 3061; Australia
+61 3 9358-5555 fax +61 3 9358-5558
e-mail murphy@macquarrie.com.au



In order to consistently bring you the highest quality, full featured products, we reserve the right to change our specifications and designs at any time.