

HelmView™ Model HV750; Model HVS750



Features

- Abs Type Approved Display For Marine and Offshore Applications on ACC, ACCU and ABCU Classed Vessels (Model HV750 Only)
- Color Display For Modern Electronic Engines and Vessel Monitoring Using SAE J1939 Controller Area Network
- Customizable For Additional Commercial Marine Applications
- Bonded 7-inch LCD Screen Viewable In Direct Sunlight
- Rugged Design That Is Simple To Use
- Video Input
- Configuration Software Option Offers Virtually Unlimited Possibilities
- Blackout Mode Option

The **HelmView HV750** is specifically designed to meet the engine monitoring needs of the Commercial Marine industry. Its durable design and easy to use interface offers a complete view of your vessel's engines. Monitor propulsion, auxiliary, transmission, and genset engines all on one display. It is equipped with the ability to switch between Day and Night mode operations and even has a blackout option. There are multiple screens to choose from and the ability to turn screens on/off to meet your specific marine application needs. The HelmView 750 has the ability to be connected to a video camera for monitoring the engine room or other important areas of the vessel.

This multi-functional display allows you to monitor multiple engines, transmissions, fuel usage, and more using only one device, thus greatly reducing operating costs. It has ten tactile push buttons that can easily be pressed with or without gloves. The HelmView 750's sunlight viewable, full-color screen makes seeing life-like gauges, alarm warnings, service codes, and video easy to view in virtually any condition. The HelmView 750 is fully programmed to display Diagnostic Trouble Codes showing critical alarms and text explanations.

The HelmView 750 display is compatible with the PowerVision Configuration Studio™ so custom software configurations can be quickly developed. With the PowerVision Configuration Studio it is easy to define the user interface screens, monitoring requirements and specifications that are unique to the Commercial Marine industry. The HelmView 750 paired with the PowerVision Configuration Studio extends custom configuration from only monitoring to equipment control, data logging, and additional alarming. You can even add custom graphics and company branding to the user interface.

Display Parameters

The following are some of the parameters displayed by the HelmView 750 in English or Metric units (when applicable, consult engine or transmission manufacturer for SAE J1939 supported parameters).

Engine RPM	Transmission Oil Temperature	Instantaneous Fuel Usage
Engine Hours	Transmission Oil Level	Trip Fuel
System Voltage	Tank Levels	Navigational Bearing
% Engine Load at the Current RPM	Course over Ground*	Active Service Codes
Coolant Temperature	Speed over Ground*	Stored Service Codes (when supported)
Oil Pressure	Longitude and Latitude*	Video
	Real Time Display*	

*NMEA GPS Antennae required

Specifications

Technical

Display: 7" / 178mm color transmissive TFT LCD

Resolution: WGA, 800 x 480 pixels, 16-bit color

Aspect Ratio: 16:9

Orientation: Landscape

Backlighting: LED, 400-500 cd / mC (50,000 h lifetime)

Microprocessor: Freescale iMX.31 32bit, 400Mhz

QNX Operating System

Flash Memory: 2 GB

RAM: 128 Mbytes SDRAM

Operating Voltage: 8-35 VDC, protected against, reverse polarity and load-dump

Power Consumption: 10w full backlight; 22w full backlight with heater (at temperatures below -10 °C)

CAN: 3 CAN ports according to CAN specification 2.0A or 2.0B; one port isolated according to NMEA 2000 (GPS)

RS485: 1 MODBUS Master/Slave port, PVA Gage

Video input: NTSC/PAL

Protocols: J1939, NMEA 2000 (GPS), CANOpen protocol support.

Connection: 5 Deutsch DT 6-pin connectors

Keyboard: 10 tactile buttons

USB 2.0 host (full speed)

Output Digital: (1) capable of syncing 500mA

Inputs: (3) 0-5 VDC analog inputs. (1) input configurable to support measurement frequencies from 2Hz - 10kHz and PWM values from 0-100% duty cycle.

Environmental

Operating Temperature: -40°C to +85°C (-40°F to +185°F)

Storage Temperature: -40°C to +85°C (-40°F to +185°F)

Protection: IP67, front and back.

Emissions: IEC 60945, 95/54/EC

Immunity: SAE J1113, ISO 11452

Vibration: Random vibration, 7.86 G_{rms} (5-2000 Hz), 3 axis

Shock: +/- 50G in 3 axis

Mechanical

Dimensions: 8.37 x 6.0 in. (212.5 x 152.3 mm) landscape

Unit Depth: 3.57 in. (90.8 mm)

Case material: Polycarbonate back case

Mounting: Front or Rear

Optional Gimbal Mount available

Dimensions

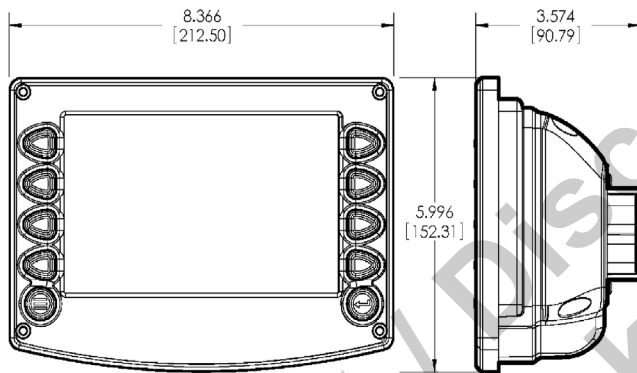

Accessories

- PowerVision Configuration Studio (78-00-0752)
- Visor Kit (78-00-0732)
- GPS Kit (78-00-0601)
- Gimbal Mounting Kit (78-00-0697)
- Contact FW Murphy for cable and wiring accessories

Service Parts

- Cover Plate (78-05-0701)
- Bezel (78-05-0720)
- Hardware Mounting Kit (78-00-0638)

How to Order

HelmView™ 750	Model #	Product #
ABS Type Approved	HV750	78-70-0525
Non-ABS	HVS750	78-70-0508