

# ASM170 MURPHYMATIC® Micro-controller Installation and Operation Instructions

ASM-03024N  
Revised 05-04  
Section 40 and 75  
(00-02-0531)



Please read the following information before installing. A visual inspection of this product for damage from shipping is recommended before installing. It is your responsibility to have a qualified person install this unit and make sure it conforms to local codes.

## GENERAL INFORMATION

### WARNING

BEFORE BEGINNING INSTALLATION OF THIS MURPHY PRODUCT

- ✓ Disconnect all electrical power to the machine.
- ✓ Make sure the machine cannot operate during installation.
- ✓ Follow all safety warnings of the machine manufacturer.
- ✓ Read and follow all installation instructions.

**CAUTION:** *Certain danger to human and to equipment such as applied in a mobile or marine application may occur if some equipment is stopped without pre-warning. It is therefore, recommended that monitored functions be limited to alarm only or to alarm before shutdown in such applications.*

### Description

The ASM170 is a state of the art, automatic engine start / stop controller with selectable warmup / cooldown, glow plug, or choke capabilities. The ASM170 operates from a 12 or 24 volt battery and can withstand voltage drops during cranking. It includes crank and rest cycles, sensing circuit for crank disconnect and overspeed, overcrank, and re crank protection on false starts. Four red LED's indicate first out shutdown from low oil pressure, high temperature, overcrank, overspeed, auxiliary input, high/low level, engine stall, and no speed signal. A fifth green LED lights when the engine has started. This same LED flashes during the rest period while the unit is cycle cranking the engine. A sixth LED lights when the multifunction output is operating. This output is programmable using the DIP switches located on the back of the unit.

The ASM170 is housed in an ABS plastic enclosure and the electronics are encapsulated in a protective epoxy resin. Due to its low cost and flexible features, it is ideal for generator or pumping applications.

### Specifications

**Power Input:** 6 to 28 VDC.

**Power Consumption Standby (AUTO):** <1mA.

**Operating Temperature:** -40 to 185 °F (-40 to +85 °C).

**Inputs:** Ground or positive inputs for high temperature, low oil pressure, High/Low Level, Auxiliary / Remote Stop sensors. (Note: The momentary start input must be at least 100 ms in duration to be recognized as a valid start.)

**Lamp Test:** When unit is powered up in Manual or Auto, the LED's light for 1 second as a test.

**Outputs:** 5A smart FET for cranking and multifunction output. Sources from battery +. 10A smart FET for Fuel Valve (Energized to Run) output. Sources from battery +. 125 ma transistor for common failure, engine run, and auxiliary output. Sinks to battery -.

**Crank Attempts:** Selectable for 3, 5, 10, or 255.

**Crank / Rest Cycle Timing:** Field adjustable 1 to 30 seconds.

**Multifunction Output:** Field programmable to one of the following options: Glowplug, Cooldown, Warmup/Cooldown, Warmup, Airgate – Overspeed Only, Airgate – Always, Choke, or Auxiliary Run output.

**Shutdown Lockout Time Delay:** Field adjustable 1 to 300 seconds. Locks out low oil pressure, high temperature, and loss of speed shutdowns on start-up.

**Crank Disconnect Speed Setting:** From 13 to 2500 Hz.

**Overspeed Trip Point Setting:** From 13 to 8500 Hz.

**Speed Sensing Input:** 1.5VAC RMS to 140 VAC RMS.

**Shipping Weight:** 1 lb. (.45 kg.)

**Shipping Dimensions:** 6.25 x 6.25 x 4.5 in. (159 x 159 x 114 mm).

### Installation Accessories

- Tools for the module mounting, such as drill and screwdriver.
- Optional Wire Harness Kit (40000138).
- 12 and 18 AWG (4.2 mm<sup>2</sup> and 1.0 mm<sup>2</sup>) wire for hook up.
- Set of wire termination tools.
- Wire Termination; such as spade terminals. 1/4" crimp-on FASTON® receptacle.

### Mounting Drill Pattern

(Do not scale or use as a template)

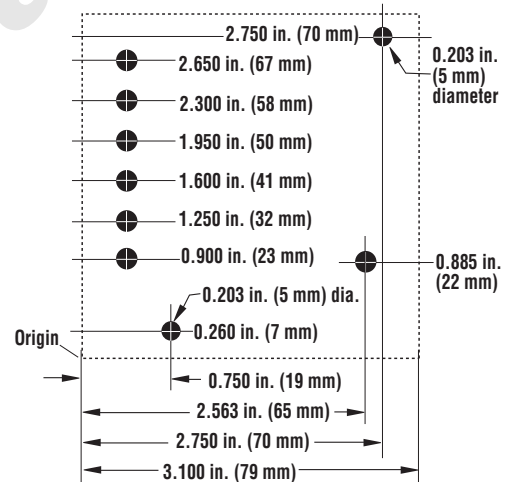

### Mounting the ASM170 Module

1. To mount the ASM170 module to your panel, drill six (0.25 in. [6mm] dia.) holes for LED indicators, and two (0.203 in. [5 mm] dia.) holes for mounting screws. See "Mounting Drill Pattern", for dimensions.
2. Insert the ASM170 module from the back of the panel into the pre-drilled holes.
3. Secure the module in place with the two (2) screws provided.

# WIRING THE ASM170

The ASM170 is a pilot duty device. The outputs are designed for control only.



**WARNING:** Disconnect ALL electrical power before beginning the wiring. STOP ALL machinery before performing the hook up. Any load connected to the panel which draws current in excess of **5 Amps** for the crank and multifunction outputs or **10 Amps** for the fuel output MUST be piloted at the load.

1. Wire the ASM170 using 18 AWG stranded wire. When wiring to the push on FET common terminal, we suggest using a larger wire size (12 AWG recommended).
2. When hooking the battery positive (+) and ground wires to the ASM170, route them directly from the battery to the unit. This will help

reduce electrical noise coupling and avoid voltage losses from other devices.

3. If a standby battery charger is installed, it must be wired directly to the battery, NOT to the ASM170. This could cause electronic "noise" produced by the charger to be coupled into the microprocessor. If the "noise" is severe, erratic operation could occur.
4. Do not route low voltage DC (battery) control wires in the same conduit as high voltage AC wires.
5. Use shielded cable for connecting the magnetic pick up to the ASM170. Ground only one end of the shield (we suggest you ground it at the engine).
6. Always place reverse bias diodes across inductive loads. This helps eliminate a source of electromagnetic noise.

External Toggle Switch  
(00009347 ONLY)

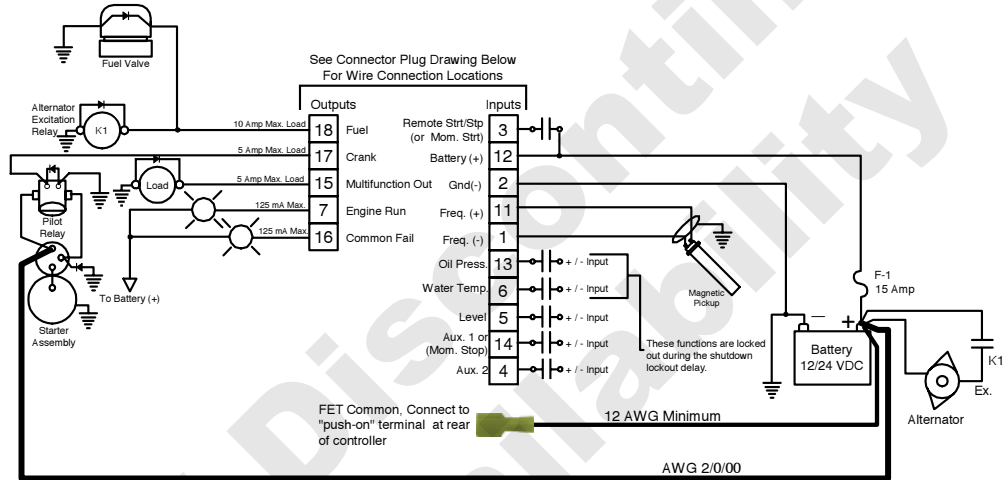
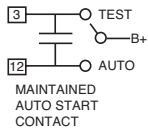

## Crimping Tools

DigiKey Part Number	WM9999-ND
Manufacturer Part Number	63811-1000
Description	Molex Universal Crimp Tool
DigiKey Part Number	WM9918-ND
Manufacturer Part Number	11-03-0044
Description	Extraction Tool Mini-Fit Jr.
DigiKey Part Number	WM9912-ND
Manufacturer Part Number	11-01-0197
Description	Crimp Tool 18-24 AWG Mini-Fit Jr.

Molex and Digikey are registered trademarks of their respective corporations.

Shell:  
MOLEX Part Number: 39-01-2200 or 39-01-2205  
20 CIRCUIT MINI FIT JR. PLUG  
Digikey WM 3709-ND



Wire Side of Plug - In Connector

Pins:  
MOLEX Part Number 39-00-0039  
or Digikey WM 2501-ND

## MAKING ADJUSTMENTS TO THE ASM170

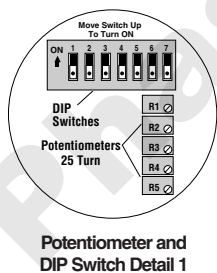

On the back of the ASM170, you will find five (5) potentiometers and seven (7) DIP switches for customizing your controller. The five potentiometers have the following functions:

- R1** = Crank / Rest Delay (1-25 seconds)
- R2** = Overspeed Frequency (13-8500 Hz)
- R3** = Crank Disconnect Frequency (13-2500 Hz)
- R4** = Multifunction Timer.
- R5** = Lockout Delay (1-300 seconds)

Number of Cranks Configuration	
3 Cranks	SW1 SW2
5 Cranks	OFF OFF
10 Cranks	ON OFF
255 Cranks	ON ON
Multifunction Configuration	
Glowlug	SW3 SW4 SW5
Shutdown	OFF OFF OFF
R1 Warmup/Cooldown	OFF ON OFF
R2 Warmup	ON ON OFF
R2 Airgate-Overspeed	OFF OFF ON
R3 Airgate-Always	ON OFF ON
R3 On/Off	OFF ON ON
R4 Auxiliary Run Output	ON ON ON
Level Input Configuration	
SW6	
Alarm Only	ON
Shutdown	OFF
Start/Stop Input Configuration	
SW7	
Momentary	ON
Maintain	OFF

- R1-Crank/Rest Delay (1-25 sec.)
- R2-Overspeed (4-8500 Hz)
- R3-Crank Stop (1-2500 Hz)
- R4-Multifunction Timer (Varies)
- R5-Lockout Delay (1-300 sec.)

### Crank / Rest Delay (R1 Pot) – Adjustable between 1 and 25 seconds

The Crank / Rest adjustment is used to vary the amount of time the cranking output is ON and OFF during the start sequence. When a start attempt begins, the controller will energize the cranking output for the amount of time set on this pot. If the engine is not sensed to have started, the controller will de-energize the cranking output for the same period of time before energizing it again. During the rest period the RUN light will flash.

### Overspeed (R2 Pot) – Adjustable between 13 and 8500 Hz

The OVERSPEED adjustment is used to set the point at which the unit will signal for a shutdown if the engine speed should reach too high an RPM. To set the OVERSPEED value, turn the OVERSPEED Pot fully clockwise and run the engine up to the maximum operating speed. Next, slowly turn the Pot counterclockwise until the engine shuts down on OVERSPEED. Now, turn the Pot clockwise two turns. This will adjust the OVERSPEED set point approximately 8% higher than the maximum engine operating speed.

### Crank Disconnect (R3 Pot) – Adjustable between 13 and 2500 Hz

The CRANK DISCONNECT adjustment is used to let the ASM170 know when the engine has started so that it will turn OFF the cranking output. Turn R3 clockwise 25 turns, and then turn R3 counter clockwise

## MAKING ADJUSTMENTS TO THE ASM170 *continued*

12 turns. Be prepared to remove the wire from the ASM170 cranking output as soon as the engine starts. Put the selector switch in the manual position, and remove the cranking wire as soon as the engine starts. Slowly turn R3 counter clockwise until the green run led turns on. Manually start the engine. If the starter does not stay engaged long enough, turn R3 one turn clockwise. Repeat this process if necessary. If the starter stays engaged too long, turn R3 one revolution counter clockwise. Repeat this process if necessary.

### Multifunction Timer Delay (R4 Pot) – Selected by dip switches 3, 4, and 5 (Ranges of adjustment explained below)

The Multifunction Timer Delay adjustment pot is used to adjust how long this output is on. There are several options for this adjustment pot. First select which function you want with the DIP switch, and then adjust this delay to the desired setting. Turn clockwise to increase and counterclockwise to decrease.

### Lockout Delay (R5 Pot) – Adjustable between 1 and 300 seconds

The lockout delay is used to ignore indications for shutdown on the pressure and temperature shutdown inputs. This delay begins timing as soon as the crank disconnect occurs. To increase the setting, turn the Pot clockwise; to decrease the setting, turn the Pot counterclockwise.

### Overcrank Adjustments (DIP Switches)

The ASM170 allows you to crank the engine 3, 5, 10, or 255 times. If after these attempts the engine fails to start, the unit will signal OVERCRANK. If the engine false starts and the ASM170 RE-CRANK's the engine, it will count this as a cranking attempt. This way, if the engine false starts the same number of times as your cranking attempts, then the unit will show OVERCRANK.

### Multifunction OUTPUT Options

There is one output on the ASM170 that can be configured to operate in a variety of ways. Below, you will find a description of each of these functions. To select the function, find it on the previous chart and flip the appropriate DIP switches to match.

**GLOWPLUG:** When this option is selected, the multifunction output is used to heat the glow plugs of a Diesel engine prior to attempting to start. Once selected, you can adjust the glowplug time delay by turning pot R4. The delay can be set from 1 to 300 seconds. When a start signal is received, the output will turn on for the amount of time set on R4. It will then turn off while the crank cycle time delay is active. If the engine fails to start, the output will turn on again after the rest delay but prior to the crank function.

**COOLDOWN:** When this option is selected, the multifunction output will turn on after a stop signal is received and stay on during the delay. It is adjustable between 1 and 300 seconds. When the delay expires, the output will turn off, along with the fuel valve, which will cause the engine to stop.

**WARMUP/COOLDOWN:** When this option is selected, the warmup delay begins timing as soon as the engine is sensed to have started. When the delay expires, the multifunction output turns on and stays on until a stop signal is received the output turns off immediately and the delay begins timing again. When it expires, the fuel valve output is turned off causing the engine to stop. This delay is adjustable between 1 and 300 seconds.

**WARMUP:** When this option is selected, the output will turn on as soon as the engine is sensed to have started and stay on throughout the delay. When the delay expires, the output will turn off. This delay is adjustable between 1 and 300 seconds.

**AIRGATE – OVERSPEED:** When this option is selected, the output will turn on only if an OVERSPEED shutdown condition is sensed. It will stay on for an adjustable period of 1 to 30 seconds.

**AIRGATE – ALWAYS:** When this option is selected, the output will turn on during any shutdown condition. It will stay on for an adjustable period of 1 to 30 seconds. This output can also be used for energized to stop applications.

**CHOKE:** When this option is selected, the output will turn on 3 seconds

into even number crank attempts. It will also immediately turn on if the engine stalls. If the engine is sensed to be running, it will turn off.

**AUXILIARY RUN OUTPUT:** When this option is selected, the output will turn on and off with the engine run output.

Number of Cranks Configuration			
	SW1	SW2	
3 Cranks	OFF	OFF	
5 Cranks	ON	OFF	
10 Cranks	OFF	ON	
255 Cranks	ON	ON	
Multifunction Configuration			
	SW3	SW4	SW5
Glowplug	OFF	OFF	OFF
Cooldown	ON	OFF	OFF
Warmup/Cooldown	OFF	ON	OFF
Warmup	ON	ON	OFF
Airgate-Overspeed	OFF	OFF	ON
Airgate-Always	ON	OFF	ON
Choke	OFF	ON	ON
Auxiliary Run Output	ON	ON	ON
Level Input Configuration			
	SW6		
Alarm Only	ON		
Shutdown	OFF		
Start/Stop Input Configuration			
	SW7		
Momentary	ON		
Maintain	OFF		

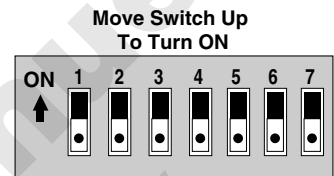

**NOTE:** DIP switch settings are read at power-up only.

### Special Features

To make the ASM170 even more flexible, it has two other special features. The feature descriptions follow:

**LEVEL INPUT CONFIGURATION:** By setting the position of DIP switch number 6, you can configure whether activating the level input causes a shutdown or just an alarm condition. If the switch is ON, the unit will just flash the HIGH/LOW LEVEL LED. If it is OFF, the unit will signal the engine to shut down.

**START/STOP INPUT CONFIGURATION:** The ASM170 can be used with a sustained start signal that closes to start and opens to stop or with a momentary start / stop signal. If DIP switch 7 is ON, a brief signal to the start input will be latched internally and the controller will signal the engine to run. A signal to the Auxiliary 1/ Stop input will latch in causing the unit to signal the engine to stop. If DIP switch 7 is OFF, the unit will signal the engine to run as long as there is a start signal present on the start input and signal it to stop when the start signal is removed.

**AUXILIARY 2 INPUT:** This input is not locked out and is indicated by a double flash on the first LED. If the Auxiliary 1 input is activated, the LED will flash once.

# SEQUENCE OF OPERATIONS

## Sequence of Operation with Panel in "AUTO"

The ASM170 module is very flexible. The basic sequence of operation follows:  
When a start signal is received, the following occurs:

- The frequency is checked relative to the crank disconnect set point. If the frequency is sensed to be above the set point, the fuel valve will turn on and the engine run light will light. The following delays will also begin timing:
  - Shutdown Lockout Delay
  - Warmup Delay (If selected)
- If the frequency is sensed to be below the set point the fuel valve will turn on, the multifunction output will turn on (if required – see MULTIFUNCTION OUTPUT OPTIONS section) and cycle cranking will begin.
  - During Cycle cranking, the Fuel Valve output is on continuously.
  - If the Multifunction output is set to glowplug, the unit will first turn on the output for the selected amount of time, turn it off then energize the start output. If the unit does not start, the start output will be de-energized through the rest delay and the run light will flash. When the rest delay expires, the multifunction output will then be energized through the delay, turn off, and the start output will be energized again. This sequence will continue until the engine is sensed to start or OVERCRANK occurs.
  - If the engine starts but then stalls, the ENGINE STALL LED will flash for 10 seconds. After the 10-second delay expires, the cycle cranking sequence will continue. These "Engine Stalls" or "False Starts" are counted as crank attempts.
    - OVERCRANK – If the engine fails to start within the selected number of crank attempts, the fuel output will be de-energized, the common fail output will be energized and the OVERCRANK LED will light. Before the module will attempt to start the engine again, this shutdown condition must be reset by moving the selector switch to the OFF position and back to AUTO.
  - If the unit successfully starts the engine by cycle cranking, the starter output will immediately be deenergized, the ENGINE RUNNING light will turn on and the multifunction output will perform any necessary functions

(see MULTIFUNCTION OUTPUT OPTIONS section). The following delays will begin timing:

- Shutdown Lockout Delay
- Warmup Delay (If selected)
- The following shutdown conditions are armed immediately:
  - OVERSPEED
  - LOW LEVEL
- Once the Shutdown lockout delay has timed out, the unit will arm the following shutdowns:
  - LOW OIL PRESSURE
  - HIGH ENGINE TEMPERATURE
  - AUXILIARY INPUT ONE
  - NO SPEED SIGNAL
- When the start signal is removed or the stop signal is sensed the unit will shutdown the engine. If the multifunction output is required to function at this time it will (see MULTIFUNCTION OUTPUT OPTIONS section). When it is ready for shutdown the fuel valve will be de-energized and the controller will await another start signal.

**SHUTDOWNS:** If the controller senses any shutdown conditions while it is running, the fuel output will be de-energized, the common fail output will be energized and the appropriate shutdown LED will light. Before the module will attempt to start the engine again, the unit must be reset by moving the selector switch to the OFF position and back to the AUTO position.

## Sequence of Operation with Panel in "MANUAL"

When the MANUAL-OFF-AUTO switch is placed in the "MANUAL" position, an automatic start signal is simulated. Therefore, the controller will operate the same as it does in "AUTO." However, it will continue to run as long as there are no signals from monitored conditions or until the MANUAL-OFF-AUTO switch is moved to the "AUTO" or "OFF" positions. There is no cooldown or airgate feature available in the manual mode. Keep in mind; it will still shut down the engine if a monitored condition occurs such as low oil pressure or high temperature.

## ASM170 I/O List

PIN#	Label	Hardware Name	Additional Information
1	Frequency-	Tach Return	Magnetic Pickup or Generator
2	Ground (B-)	B-	Battery Minus
3	Start (Manual)	Input 1	Battery Plus Only
4	Aux Input 1	Input 6	+/- Input (Only Common Fail Output Turns on when activated-Not Locked Out)
5	Level	Input 5	+/- Input SW6 Shutdown or Auto Reset Alarm
6	High Temperature	Input 3	+/- Input
7	Engine Run Out	Output 5	125 mA Sinking
8	Not Used	Output 6	125 mA Sinking-When Input 6 is active, this pin sinks to ground
9	None	FET Power	No Hookup
10	None	FET Power	No Hookup
11	Frequency +	Tach	Magnetic Pickup or Generator
12	Auto	Battery (+)	Auto Position of MOA
13	Low Oil Pressure	Input 2	+/- Input
14	Aux Input 1/Remote Stop	Input 4	+/- Input
15	Multifunction Output	Output 3	5 AMP FET
16	Common Shutdown Output	Output 4	125 mA Sinking
17	Crank Output	Output 1	5 AMP FET
18	Fuel Output	Output 2	10 AMP FET
19	None	FET Power	No Hookup
20	None	FET Power	No Hookup
Blade	FET Common	FET Power	Push On for FET Supply Power (20 AMPS)

## Warranty

A limited warranty on materials and workmanship is given with this FW Murphy product.  
A copy of the warranty may be viewed or printed by going to [www.fwmurphy.com/support/warranty.htm](http://www.fwmurphy.com/support/warranty.htm)



**FW Murphy**  
P.O. Box 470248  
Tulsa, Oklahoma 74147 USA  
+1 918 317 4100  
**fax** +1 918 317 4266  
**e-mail** [sales@fwmurphy.com](mailto:sales@fwmurphy.com)  
[www.fwmurphy.com](http://www.fwmurphy.com)

**CONTROL SYSTEMS & SERVICES DIVISION**  
P.O. Box 1819; Rosenberg, Texas 77471; USA  
+1 281 633 4500 **fax** +1 281 633 4588  
**e-mail** [sales@fwmurphy.com](mailto:sales@fwmurphy.com)

**MURPHY DE MEXICO, S.A. DE C.V.**  
Blvd. Antonio Rocha Cordero 300, Fracción del Aguaje  
San Luis Potosí, S.L.P.; México 78384  
+52 444 8206264 **fax** +52 444 8206336  
Villahermosa Office +52 993 3162117  
**e-mail** [ventas@murphymex.com.mx](mailto:ventas@murphymex.com.mx)  
[www.murphymex.com.mx](http://www.murphymex.com.mx)

**FRANK W. MURPHY, LTD.**  
Church Rd.; Laverstock, Salisbury SP1 1QZ; U.K.  
+44 1722 410055 **fax** +44 1722 410088  
**e-mail** [sales@fwmurphy.co.uk](mailto:sales@fwmurphy.co.uk)  
[www.fwmurphy.co.uk](http://www.fwmurphy.co.uk)

**MURPHY SWITCH OF CALIFORNIA**  
41343 12th Street West  
Palmdale, California 93551-1442; USA  
+1 661 272 4700 **fax** +1 661 947 7570  
**e-mail** [sales@murphyswitch.com](mailto:sales@murphyswitch.com)  
[www.murphyswitch.com](http://www.murphyswitch.com)

**MACQUARRIE CORPORATION**  
1620 Hume Highway  
Campbellfield, Vic 3061; Australia  
+61 3 9358 5555 **fax** +61 3 9358 5558  
**e-mail** [murphy@macquarrie.com.au](mailto:murphy@macquarrie.com.au)



*In order to consistently bring you the highest quality, full featured products, we reserve the right to change our specifications and designs at any time.*