

MURPHY



iGUARD

Digital Generator Set Controller

Installation and Operations Manual

00-02-0522
04-06-11
Section 75

In order to consistently bring you the highest quality, full featured products, we reserve the right to change our specifications and designs at any time. The latest version of this manual can be found at www.fwmurphy.com.

Warranty - A limited warranty on materials and workmanship is given with this FW Murphy product.
A copy of the warranty may be viewed or printed by going to <http://www.fwmurphy.com/warranty>



Please read the following information before installing.

BEFORE BEGINNING INSTALLATION OF THIS MURPHY PRODUCT:

- Disconnect all electrical power to the machine.
- Make sure the machine cannot operate during installation.
- Follow all safety warnings of the machine manufacturer.
- Read and follow all installation instructions.
- Please contact FW MURPHY immediately if you have any questions.

Table of Contents

Introduction	1
Product Description	1
User Interface and Navigation	1
iGUARD Operating Instructions	3
Operating Sequence	3
Programming the iGUARD from the Keypad	5
Settings and Definitions	8
Operating Parameters	8
Communication Parameters	12
Miscellaneous Parameters	13
Engine Parameters	16
Generator Parameters	18
Digital Inputs and/or Relay Outputs	21
Analog Inputs	30
Manufacturers Specifics	36
iGUARD Typical Installation and Mounting	38
iGUARD Electrical Installation	41
Electrical Hook up	41
Energy Monitoring Board (EMB)	45
Installing the Mimic/Annunciator DM/A	50
DM/A Mimic/Annunciator Versions	50
Specifications	58
Standard Components	58
iGUARD Options and Accessories	59

(THIS PAGE INTENTIONALLY LEFT BLANK)

Phase-out / Discontinued Product
Check Availability

Introduction

This document is designed to support a user in getting familiar with the iGUARD Digital Generator Set Controller and how to navigate the interface, modify the settings and install and operate the controller. Before attempting to set up the controller, be sure to read and understand this manual in its entirety.



Product Description







Description

The iGUARD controller is a high performance, state of the art, digital generator set controller. This robust controller features high-speed microprocessors, and high accuracy AC measurements. The iGUARD is a menu driven system, organized by "stacks", with "sub-stacks" where required. User connections are made via the plug in connectors on the rear of the controller. The iGUARD controller has a textured finish; UV stabilized polycarbonate injection molded housing, and is sealed with an "o" ring to help protect the iGUARD from the environment. There is a back cover protecting the Energy monitoring Board (EMB) to prevent contact with circuit board components and potentially harmful AC voltage wiring.

User Interface and Navigation

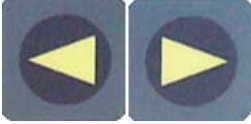
The keypad on the iGUARD is a capacitive touch sensing system. There are no mechanical switches to wear or stick, and the technology has been time proven in many applications. It operates in extreme temperatures, with gloves, through ice, snow, mud, grease, etc., and it allows complete sealing of the front of the iGUARD. It does operate slightly differently than a membrane keypad, in that there is no tactile feedback. The 'key is pressed' feedback is provided by momentarily beeping the audible alarm. The keys on the keypad do the following functions:

	START	In Manual mode pressing the start pad will cause the engine to start. In automatic mode the screen will display an error message that system must be in manual mode to start with the start button.
	STOP	In automatic or manual mode pressing the stop pad will stop the set. The system is forced into a manual mode, and will not autostart until returned to automatic mode.
	Auto/Manual	Selects manual (sometimes-called local) operation or automatic mode (system monitors a digital input for a start signal).

	Acknowledge/Alarm	For warnings that do not cause a shutdown, pressing this pad will clear the alarms active at that moment. If the conditions subsequently clear and re-occur or if additional warnings occur, the common alarm output will come back on.
	Up / Down Arrows	In program mode scrolls the menu selections and also scrolls through the choices for a given parameter.
	Left / Right Arrows	In normal operation steps forward/backward through the screens available in the active submenu
	Next	In normal operation steps forward through the main menu selection
	Back	In normal operation steps backward through the main menu selections.
	Enter	In program mode, pressing Enter will allow a variable to be changed, and then pressing Enter again will accept the displayed /new value.
	Exit	In normal operation returns the system to the main (default) screen. In program mode cancels any changes made unless the "Enter" pad has already been pressed.

iGUARD Operating Instructions

Operating Sequence

The iGUARD controller, while reprogrammable, follows a standard operating sequence. This operating sequence is basically a set of machine states that happen in a pre-determined order. Machine states can be set to zero if not needed, or adjusted to fit the application. For the basic operating sequence, see the iGUARD Sequence Appendix in the Installing the Mimic/Annunciator DM/A section, this document. The iGUARD operating sequence includes the following modes:

Ready to Start Mode	Automatic start mode ready for a contact closure to initiate an automatic start and run sequence.
Prestart Delay Mode	A timer used to prevent nuisance starts, or to warn nearby personnel that automatic equipment is about to start (set to 0 to bypass).
Prelube Mode	In larger generators there may be a requirement for automatic lubrication prior to cranking (set to 0 to bypass).
Preheat	Timer set to provide the correct amount of precrank operation of the air intake heaters used to facilitate starting in cold conditions. (Set to 0 to bypass).
Cranking / Crank Rest Mode	Engine is attempting to start and will go through the number of selected starting attempts.
Crank Disconnect / Engine Running Mode	Engine speed is greater than the crank disconnect.
Warmup Mode	Timer to allow system to run unloaded for selected time (set to 0 to bypass).
At Load Mode	Generator is running at load.
Power Good Mode	This mode is to prevent nuisance start/stops. The controller continues running but monitors the remote start contact while in this mode. The power good timer must expire before the system can proceed to cooldown. Any further call to run resets the power good mode timer to its preset value.
Cooldown Mode	Generator runs unloaded for a preset time.

Energized to Stop	The Energized to Stop timer is ON and the Energized to Stop output is active.
Stopped Mode	Generator has come to a complete stop.
Postlube Mode	<p>In larger generators there may be a requirement for automatic lubrication after a normal start/run/stop cycle before the engine can be restarted (set to 0 to bypass). After postlube, the system returns to Ready to start. Additionally there are two fault shutdown modes:</p> <ul style="list-style-type: none"> • Shutdown / Lockout with Cooldown Mode - In the case of some faults the controller will open the "at load" contact and then go through a normal cooldown and stop sequence, but will not allow an automatic restart without a system reset. • Immediate Shutdown/Lockout (no Cooldown) Mode - Because of the severity of most faults, the controller will cause an immediate Shutdown/Lockout without a cooldown period, and will not allow an automatic restart without a system reset.
Shutdown / Lockout with Cooldown Mode	In the case of some faults the controller will open the "at load" contact and then go through a normal cooldown and stop sequence, but will not allow an automatic restart without a system reset
Immediate Shutdown/Lockout (no Cooldown) Mode	Because of the severity of most faults, the controller will cause an immediate Shutdown/Lockout without a cooldown period, and will not allow an automatic restart without a system reset.

Programming the iGUARD from the Keypad

The iGUARD controller can be programmed in two separate ways. Most setup can be done from the front panel. There are some parameters, such as changing passwords that require the use of the iGCON software tool. The iGUARD programming menus can be accessed at any time by pressing the left and right arrows at the same time. This will bring up the password menu:



The factory defaults (and what they allow access to) for the various levels of password are:

Access Security - Allows input of 4-character security code.

- **PASØ - No operational Access.** It allows viewing of the data screens but parameters cannot be edited.
- **PAS1 - Operational Access.** It allows Manual Start and Stop but parameters cannot be edited.
- **PAS2 - Parameter View Access.** Allows for viewing of all parameters and editing of the following parameter settings:
 - Change Language
 - Key Sensitivity Level
 - Back Light On/Off
 - Ack Maintenance Timers
 - Enable Beeper
 - Select Pressure Units
 - Select Temperature Units
 - Modify Date
 - Edit Clock Start and Stop Timers
- **PAS3 - Parameter Edit Access.** Allows for viewing and parameter editing but does not allow calibration of AC.
- **PAS4 - Calibration Access.** Allows calibration of the AC parameters.
- **PAS5 - kW Limit Edit and Config Select Access.** Allows editing of kW limits and various communication addresses.

What to do if you lose your Password

Press NEXT until you see the screen with a graphic display of the Murphy logo. Press NEXT once to go to the system information screen.

FWMURPHY - iGUARD
WWW.FWMURPHY.COM
SALES@FWMURPHY.COM
(918) 317-4100
PN▶ 75-70-0185
SN▶ U04-A-0021
SU▶ 1.23
02:19:06PM WED 06/04/03

Write down the serial number, the current date, and time showing on the real time clock display, and contact us (918) 317-4100, ask for technical support). We will provide a temporary password that will allow you to access the system to recover the passwords.

Acknowledging Maintenance Timers

Status/ Warning Screen - You may see this warning/status message:

WARNING /STATUS
MAINTENANCE REQUIRED
RUNNING LOADED
AUTO

This is information that one or more of your maintenance reminder timers has expired. To acknowledge the warning and reset the timer, enter the programming mode, and go to the Miscellaneous Parameters screen.

MISCELLANEOUS PARAMETERS
5-OIL LIFE
0100 HRS
0112.6H MAINT. REQUIRED!
6-OIL FILTER LIFE
7-BELT LIFE
▲▼ -CHANGES ▶-RESET
ENTER-ACCEPT EXIT-QUIT

Press Enter and the screen should change to this display with the number quantity flashing:

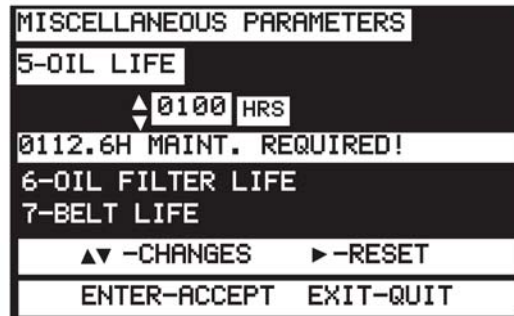

Press the right arrow to reset and the display should change to:

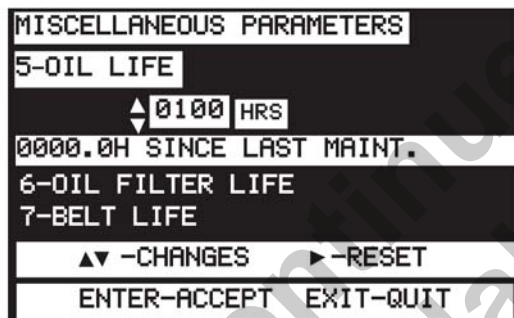

Each timer can be acknowledged as it expires, or whenever the maintenance is done, if it precedes the timer reaching 0.

Displaying Data

Use the Auto scroll function.

To turn the Auto scroll function ON, press the ENTER and NEXT keys at the same time. There are three Auto scrolling speeds temporarily displayed on the top line each time ENTER and NEXT keys are pressed (4 seconds, 8 seconds, 12 seconds). To select a different speed, simultaneously press the ENTER and NEXT keys again to go to the next speed section. To turn off the Auto scroll function press the EXIT and NEXT keys at the same time. If the iGUARD is left on a non-scroll screen (like the Warnings/status screen) it will display only the Warning/status screen.

When Programming

Touching the left arrow takes you immediately to the "TOP" of the program selection list. The right arrow takes you immediately to the "BOTTOM" of the selection list.

Settings and Definitions

Operating Parameters

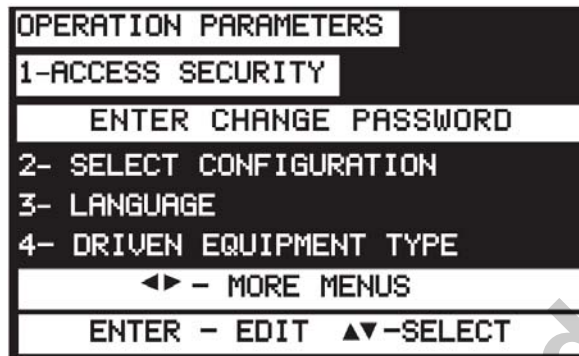

To bring up the iGUARD Programming Screen, press the Left and Right arrow keys simultaneously. After gaining access to this screen, you can use the Left, Right, Up and Down keys to navigate from column to column and to adjust the values or change characters displayed. Press Enter when password is correct.

The security level is shown on the bottom of the display. Press Exit to bring up the Parameters screen.

1. Access Security - Allows input of 4-character security code.

- **Level - No operational Access.** It allows viewing of the data screens but parameters cannot be viewed or edited.
- **Level 1 - Operational Access.** It allows Manual Start and Stop but parameters cannot be viewed or edited.
- **Level 2 - Parameter View Access.** Allows for viewing of all parameters and editing of the following parameter settings:
 - Change Language
 - Key Sensitivity Level
 - Back Light On/Off
 - Ack Maintenance Timers
 - Enable Beeper
 - Select Pressure Units
 - Select Temperature Units
 - Select Temperature Units
 - Date Display Format
 - Modify Date
 - Edit Clock Start and Stop Timers

- **Level 3 - Parameter Edit Access.** Allows for viewing and parameter editing but does not allow calibration of AC.
- **Level 4 - Calibration Access.** Allows calibration of AC parameters.
- **Level 5 - kW Limit Edit and Config Select Access.** Allows editing of kW limits and various communication addresses.

2. Language - Allows selection of language used to display text.

- a. English (Default)
- b. Spanish
- c. etc. (future expansion)

3. Driven Equipment Type - Allows selection of type of equipment that is driven by the engine.

- a. None (engine only, ignores all AC parameters)
- b. AC Alternator (Genset) (Default)

4. Key Sensitivity Level - Determines how sensitive the touch pad keys are for your application.

- a. Low*
- b. Normal (Default)
- c. High

5. Default Screen - When the system is running this selects the screen that will show.

- Event History
- Warnings / Status
- Engine / Gen Status
- Meters
- Nominal Meter
- Splash Screen
- Information
-

NOTE: * Newer versions of the controller/software will not have a “LOW” sensitive selection.

6. Lamp Test - Tests LCD.

7. LCD Backlight - Turns the iGUARD display backlight off, unless an error condition activates the common visual alarm.

- a. Disabled
- b. Enabled (Default)

8. Guard Beeper - Keypress indication and/or audible warning buzzer.

- a. Disabled
- b. Enabled - Beeps with each keypress, sounds for errors. (Default).

9. Pressure Units - User selection of display units.

- a. PSI (Default)
- b. kPa
- c. bar

10. Temperature Units - User selection of display units.

- a. Fahrenheit (Default)
- b. Celsius

11. Date Display - Format Selectable.

- a. American Style (Default)
- b. European Style

12. Event Types to record.

- a. All events (Default)
- b. Shutdown events only

13. Clear Event History - Erases all stored history events.

14. Standby Mode Timer - When the timer expires, the system goes into a lower power standby mode. After it times out the LCD screen changes to a text message, the blue LCD backlight is turned off, and the Energy Monitoring board is de-powered. Any keypress or a remote call to run wakes the unit up. Value can be set between 30 seconds and 59 minutes 30 seconds or can be set to OFF.

15. Run to Destruct - When run to destruct is enabled, the system will only sound alarms for errors, instead of shutting down. Since this could lead to the destruction of the equipment or the load, there is both a menu selection and a jumper that must be physically cut (see schematic diagram), making this a deliberate choice.

- a. **Disabled** (Default)
- b. **Enabled**

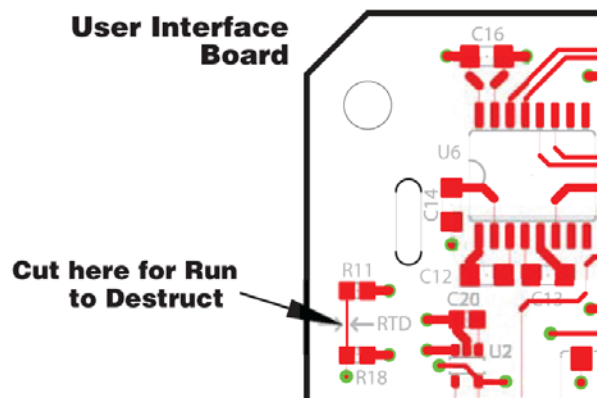

16. Edit Time and Date - Allows user to

adjust

time and date of iGUARD.

17. Input - Output Test - Shows the status of the analog inputs, digital inputs, and relay outputs.

- a. The analog input screen shows any change in the inputs. For example if the resistance value of a resistive sender changes, the counts will change.
 - i. Analog channel number
 - ii. Name/setup label
 - iii. Actual value
- b. The digital input screen shows the status of the digital inputs.
 - i. Digital Input Number
 - ii. Name/setup label
 - iii. Made/open
- c. Relay output status allows the forcing of any relay out. The screen shows:
 - i. Relay output number
 - ii. Name/setup label
 - iii. State

NOTE: Analog values, digital input, and relay status may be read on these screens at any time. The relays may only be forced in “Manual Mode” while not running.

18. Reset Configuration - Allows user to force a complete reset to a known state and clears all programming and customization.

19. Operation Mode

- a. Manual, Auto, NFPA - If not in Auto, you’ ll get Not-In-Auto alarm.
- b. Manual, Auto No Warning - It disables the Not-In-Auto alarm.
- c. Manual Mode Only - Can only be started from the front keypad.

20. Duplicate Senders - Allows ‘one only’ or more than one sender for engine pressures and temperatures.

21. Repeater #1 (set to Mimic as Default)

- a. Set as Mimic Allows control capabilities without programming.
- b. Set as Annunciator Allows viewing without control.

22. Repeater #2 (set to Mimic as Default)

- a. Set as Mimic Allows control capabilities without programming.
- b. Set as Annunciator Allows viewing without control.

23. Winter/Summer Setpoint

- a. Set Below Setpoint - If temperature is below setpoint, during start up, automatic pre-heating begins.
- b. Set Above Setpoint – If temperature is above setpoint, during start up, pre-heating is bypassed.

Communication Parameters

1. **J2 Protocol type** - Selects the function that the selectable comm. port (on J2) will perform

- a. RS-232 iGUARD config
- b. RS-485 Modbus server

2. **Modbus Server (SLAVE)” address** - Sets the address of the Modbus server (247 is default)

3. **RS-485 Server (SLAVE) bit frame** - Sets the number of start, data & stop bits for serial communications via RS-485 Modbus

- a. 10 bits N-8-1
- b. 11 bits N-8-2

4. **Server (SLAVE) Baud Rate** - sets the number of start, data & stop bits for serial communications via RS-485 Modbus

- a. 9600
- b. 19200
- c. 38400 (Default)

5. **RS-485 Client (MASTER)” bit frame** - sets the number of start, data & stop bits for serial communications via RS-485 Modbus

- a. 10 bits N-8-1
- b. 11 bits N-8-2

6. **Client (MASTER)” Baud Rate** – communication speed on the RS-485 Client (Master) port

- a. 9600
- b. 19200
- c. 38400 (Default)

NOTE: Be aware that when using the iGUARD to drive PowerView analog gages or the Remote I/O board, those devices only operate at 38400 baud.

7. Modem Connection - Sets the com port for RS-232 based modem communications

- a. Enabled
- b. Disabled (Default)

Miscellaneous Parameters

Review the materials supplied with the engine/ECU by the manufacturer to become familiar with the specifics of your engine.

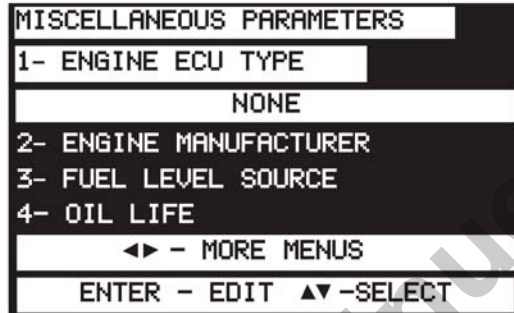

1. Engine ECU Type - Selects which ECU communications interface will be used to provide engine parameters.

- a. None (mechanically governed/controlled engine) (Default)
- b. J1939

2. Crank Cut Type - Selects the primary crank and the secondary crank cuts. The options are as follows:

Primary	Secondary
J1939	MPU
J1939	AC Freq
J1939	Digit input
J1939	None
MPU	J1939
MPU	AC Freq
MPU	Digit input
MPU	None
AC Freq	J1939
AC Freq	MPU
AC Freq	Digit input
AC Freq	None

3. ECU Address Claim

- a. None Required
- b. Single ECU
- c. Multiple ECU's

4. Engine Manufacturer - Selects engine manufacturer.

	Manufacturer		Manufacturer
a	Caterpillar	i	Isuzu
b	Cummins	j	Kubota

c	Deere	k	Lister-Petter
d	Detroit	l	Mercedes
e	Deutz	m	Perkins
f	Ford	n	Volvo
g	GM	o	Other (Default)
h	Hatz		

NOTE: Caterpillar, Cummins, Deere, Detroit, Deutz, Ford, GM, Hatz, Isuzu, Kubota, Lister-Petter, Mercedes, Perkins, Volvo are registered trademarks of their respective corporations

5. J1939 Crankcut Count - Is the number of consecutive measurements of the RPM above the Crankcut RPM, required to achieve crank disconnect.

6. Fuel Level Source - Select level source.

- a. None (Default)
- b. J1939
- c. Analog Input

7. Oil Life - Sets service interval timer for end user maintenance reminder. (Default 100 hours)

8. Oil Filter Life - Sets service interval timer for end user maintenance reminder. (Default 100 hours)

9. Belt Life - Sets service interval timer for end user maintenance reminder. (Default 100 hours)

10. Battery Life - Sets service interval timer for end user maintenance reminder. (Default 100 hours)

11. Fuel Filter Life - Sets service interval timer for end user maintenance reminder. (Default 100 hours)

12. Air Filter Life - Sets service interval timer for end user maintenance reminder. (Default 100 hours)

13. Overhaul Life - Sets service interval timer for end user maintenance reminder. (Default 1000 x 10 hours)

Engine Parameters



1. **Pre-Autostart Delay** - When system is in automatic mode, sets how long unit waits after a remote run signal is active before proceeding with automatic start sequence. (Default 5 seconds, set to zero to bypass.)
2. **Pre-Heat Type** - Determines how long the preheat output is active.
 - a. None - No preheat. (Default)
 - b. Pre-Crank - For strictly the preheat timer length.
 - c. Crank Through - Preheat for the preheat timer + crank time.
 - d. Bypass Timer - Preheat + crank + start up lockout bypass.
 - e. Warm-Up - Preheat + crank + start up lockout bypass + warm-up.
3. **Pre-Lube Time** - Amount of time a prelube output stays on prior to allowing a start. (Default 0 sec.)
4. **Pre-Heat Timer** - Amount of time that an engine is preheated prior to cranking. (Default 0 sec.)
5. **Purge Crank Time** - In gaseous-fueled engine applications, a purge crank is used to prevent gas build up and vent any accumulated gaseous fuel from the system so that it will start with a known condition. The engine cranks for a pre-settable time with the fuel output de-energized. (Default 0 sec.)
6. **Crank Time** - In an automatic crank cycle the longest time that the engine cranking motor can be energized. (Default is 15 sec.)
7. **Crank Rest Time** - In an automatic crank cycle, the time that the engine cranking motor is off between crank attempts. (Default 15 sec.)
8. **Start Attempts** - The maximum number of times that the engine cranking motor is energized without a successful engine start. (Default 3 cycles)
9. **Startup Bypass Time** - Temporarily disables the low engine oil pressure, high engine temperature and various other shutdown faults until the engine can come to a running condition. (Default 15 sec.)

- 10. Warm-Up Load Delay** - How long the engine /generator will run before it closes the "AT LOAD" contacts. (Default 0 sec.)
- 11. Nominal RPM** - Nominal operating RPM (1800 RPM for 60 Hz, 1500 RPM for 50 Hz). (Default 1800)
- 12. Engine Overspeed** - Engine overspeed setpoint. (Default 1980 RPM [110%])
- 13. Engine Underspeed** - Engine underspeed setpoint. (Default 1620 RPM [90%])
- 14. Engine Cooldown** - How long engine will run after the remote run demand is removed. There are some Generator faults that will also go through a normal cooldown and proceed to lockout. (Default 0 min.)
- 15. Post-Lube Time** - Length of time after the genset has completed a normal run that any post-run lubrication system is to be activated. Set will not restart until timer expires. (Default is 0 sec.)
- 16. Flywheel Tooth Count** - Number of Flywheel teeth. (Default 168)
- 17. Crank Termination RPM** - Speed to stop cranking the engine. Also considered the minimum engine run speed. (Default 600 RPM)
- 18. Oil Pressure Warning** - Oil pressure at which the controller activates a warning indication. (Default 25 PSI)
- 19. Oil Pressure Shutdown** - Oil pressure at which the controller shuts down the system due to low oil pressure. (Default 20 PSI)
- 20. High oil temperature warning** - Oil temperature at which the controller will activate a high oil temperature warning alarm. (Default 245°F)
- 21. High oil temperature shutdown** - Oil temperature at which the controller shuts down the system due to high oil temperature. (Default 250°F)
- 22. Low Eng. Temp. Warning** - Coolant temperature at which the controller will activate a low temperature warning alarm. (Default 70°F)
- 23. High Eng. Temp. Warning** - Coolant temperature at which the controller activates a warning indication. (Default 215°F)
- 24. High Eng. Temp. Shutdown** - Coolant temperature at which the controller shuts down the system due to high temperature. (Default 220°F)
- 25. Battery Weak** - Voltage setpoint for average battery voltage during cranking. Battery voltage that falls below this setpoint usually indicates either a bad battery or bad connections. (Default 8 VDC)

26. Battery Low Warning - Low battery voltage setpoint. Voltage equal to or less than this setpoint in normal (non-cranking) operation indicates battery needs charging. (Default 11.5 V)

27. Battery High Warning - Battery voltage equal to or greater than this indicates overcharging of battery. (Default 14 V)

28. Fuel Low Warning - Fuel level warning setpoint. (Default is 35%)

29. Fuel Low Shutdown - System shuts down when fuel level reaches this amount. (Default 5%)

30. Energize to stop - In systems that require an energize-to-stop signal, this controls how long the stop output is on. (Default is 0 sec)

31. RPM per Hertz - In systems with no magnetic pick up, engine RPM is a fixed constant, based on the AC frequency, allowing an RPM display. (Default is 30)

Generator Parameters

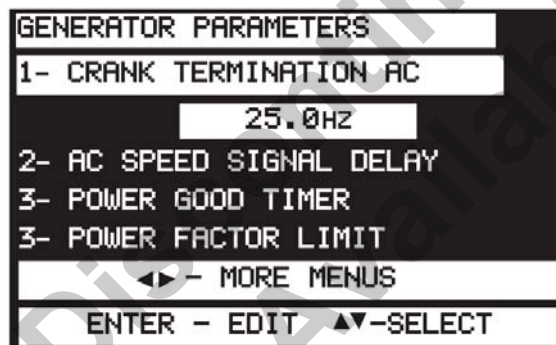

1. Crank Termination AC - When using the AC frequency for a speed source, this is the equivalent to crank termination RPM. (Default 20 Hz)

2. AC Speed Signal Delay - Delay to allow excitation of the alternator. (Default 3 sec.)

3. Power Good Timer - A timer to avoid nuisance start/stop cycles. At the end of a normal automatic cycle, when the remote start signal is no longer active, this timer must expire before the system will proceed to cooldown. (Default 0 sec.)

4. CT Ratio - Current transformer ratio (xxx:5). (Default is 300:5) The iGUARD uses standard 5A output CT's.

5. Load Bypass Timer - Timer for bypass of load related alarms to allow load stabilization. (Default 5 sec.)

6. Calibration Voltage - Allows field recalibration of AC voltage inputs. AC voltages here are always measured Line to Neutral, even if the normal display is set for line to line.

7. Calibration Current - Allows field recalibration of AC current inputs.

8. Grounded CT's - The energy monitoring board allows termination of the CT's in two ways. The CT's may be wired with both leads from each CT brought back to the EMB, or by bringing one lead from each CT, tying the other leads together, and grounding them. This is called grounded or commoned CT's. If your installation can bring all six leads back to the EMB, that is the method that we recommend. If the application can't, and the CT's have one lead from each CT all tied together, then this selection needs to be set to "YES".

- a. No (Default)
- b. Yes

9. Nominal Voltage Source - Allows selection of display voltage as line-to-line or line to neutral.

- a. Line - Line (Default)
- b. Line - Neutral

10. Indicate Reverse Power - Allows user to mask CT orientation alarms by disabling reverse power/current indication

- a. Yes (Default)
- b. No

11. Phase Selection - Common generator configurations.

- a. 3Ph High Wye
- b. 3Ph Low Wye
- c. 3Ph Wye (Default)
- d. 3Ph Delta
- e. Center Tap Delta
- f. Single Phase

There are a number of ways to connect AC to the iGUARD. It is important to understand the options and their meaning.

In the case of alternators that can be reconnected, the AC voltage and current are measured at the non-neutral junction of the coils, and if "3ph high wye" is selected the coils are connected in series. The actual output voltage will be 480 VAC, but the voltage measured at the coil junction will be 240 VAC. The reading must be multiplied by 2 to display the output voltage correctly.

In the case of a "3ph low wye", the AC voltage and current are still measured at the non-neutral junction of the coils, but the coils are arranged in parallel. The AC voltage output is 240 VAC but, the current is twice the reading from the CT.

When using a non-reconnectable alternator or the application doesn't include a voltage output select switch, "3ph wye" displays output voltage and output current directly (default setting).

When using a Center Tapped Delta (3-phase output is 240VL-L, but L-N is 120,208,120L1, L2, and L3 respectively) this is the setup to select. Single phase (two lines and a neutral) of any configuration.

12. **Generator Over Freq** -Over-frequency shutdown setpoint. (Default is 65 Hz)
13. **Generator Under Freq** - Under-frequency shutdown setpoint. (Default is 55 Hz)
14. **Nominal Voltage** - "OK" voltage as measured at the "Nominal Voltage source". (Default is 480VAC)
15. **Over-Voltage Trip** - Over voltage shutdown setpoint. (Default is 110%)
16. **Under-Voltage Trip** - Under-voltage shutdown setpoint. (Default is 90%)
17. **Power Factor Limit** - Maximum limit for power factor. Will shutdown generator if setpoint is exceeded. (Default .8 set to OFF to bypass)
18. **IDMT Curve**- Thermal protection for AC Alternator Off (Default) inverse; very inverse; extremely inverse; long time inverse.
19. **IDMT Pickup Current** -Current setpoints for Thermal Protection to start (Default is 300A)
20. **Maximum Inst. Over-Current** - Over-current shutdown setpoint. (Default is 300A) Instantaneous
21. **PT Ratio** -In system with L-L voltages > 600V, Potential transformers must be used to prevent voltages greater than design from being applied to the energy monitoring board. (xxx:1) 4200V:120V = 35:1 ratio, 480:240=2 ETC. (Default is 1.00:1)
22. **kVA Limit** -Limits kVA output of generator. Requires a level 5 password. (Default is 200 kVA.)
23. **Over freq. Warn time** - Delay timer before system shuts down on over frequency (Default is 3 sec)
24. **Over voltage warn time** - Delay timer before system shuts down on over voltage. (Default is 3 sec)
25. **UF, UV, OC warn time** - Delay timer before system shuts down on Under Frequency, Under Voltage or Over Current. (Default is 3 sec)

Digital Inputs and/or Relay Outputs

When wired to control the voltage regulator and the warmup speed, the Run/Idle switch input (or the warmup timer) essentially inhibits AC speed detection in the idle and/or warmup mode. NFPA-110 requires a secondary speed signal source to prevent crank re-engagement. If the iGUARD is being used in an NFPA-110 / 99 application, and there is a low speed warmup/idle required, the AC frequency cannot be used as a primary nor secondary speed signal source.

As this implies, there are no AC frequency or voltage based alarms or shutdowns available during the low speed idle or warmup period. Since NFPA applications assume that there is no warmup period (the requirement for a minimum - and therefore externally maintained jacket coolant temperature) this should pose no problem for NFPA-110/NFPA-99 applications, unless the application is in some way special, or the local inspector is making exceptions based on intended use, or some other special circumstance.

The speed signals can come from the ECU, a magnetic pickup, or a separate speed switch type device. When using a low speed idle (a run/idle switch input) for warmup in non-NFPA applications, there are no special requirements for a secondary speed signal source.

When using a low speed idle (a run/idle switch input) for warmup in non-NFPA applications, there are no special requirements for a secondary speed signal source.

Input Parameters - (Defaults Shown)

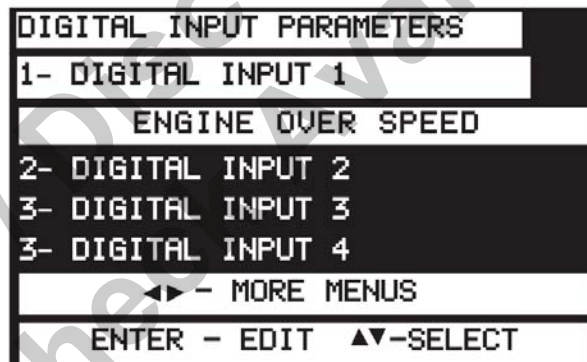

1. **Digital Input 1** - Engine Overspeed.
2. **Digital Input 2** - Crank Termination.
3. **Digital Input 3** - User Input 1.
4. **Digital Input 4** - User Input 2.
5. **Digital Input 5** - User Input 3.
6. **Digital Input 6** - User Input 4.
7. **Digital Input 7** - User Input 5.

8. **Digital Input 8** - User Input 6.
9. **Digital Input 9** - Remote Call to Run. (Transfer switch input)
10. **Digital Input 10** - Low Lubrication Oil Level.
11. **Digital Input 11**- Low Coolant Level.
12. **Digital Input 12** - Low Fuel Level Warning.
13. **Digital Input 13** - Fuel Leak.
14. **Digital Input 14** - Battery Charger AC Fail.
15. **Digital Input 15** - Emergency Stop N/O.
16. **Digital Input 16** - Air Damper Closed.
17. **Digital Input 17** - Generator Config 1.
18. **Digital Input 18** - Generator Config 2.
19. **Digital Input 19** - Generator Config 3.
20. **Digital Input 20** - Generator Config 4.
21. **Digital Input 21** - Generator Config 5.
22. **Digital Input 22** - Generator Config 6.
23. **Digital Input 23** - Fuel Filter Restriction.
24. **Digital Input 24** - Air Filter Restriction.

Menu Selections for Digital Inputs

1. **Disabled** - Not used
2. **Remote Call to Run** - In automatic mode, when this input is grounded, the system will initiate an automatic start sequence.
3. **Remote Alarm Acknowledge** - When grounded will acknowledge (silence) remote audible alarms.
4. **Engine Overspeed** - When grounded, initiates an immediate shutdown and lockout and displays "Engine overspeed" as cause of shutdown.
5. **Crank Termination** - When active will cause immediate cessation of cranking, and no cranking can occur while this input is active.

6. Low Fuel Level (warning) - When active, system indicates "low fuel level" alarm and closes the alarm contacts, but does not shutdown.

7. Fuel Leak - When active, indicates a fuel leak in the fuel containment basin, and causes an immediate shutdown.

8. Fuel Filter Restriction - When active, indicates fuel filter restriction and will shutdown if running or will not start.

9. Air Damper Closed - When active, indicates that the air shutdown damper is closed and the system will not start. An input programmed for this function causes an immediate shutdown if it becomes active when the system is running.

10. Air Filter Restriction - When active, indicates air filter restriction warning.

11. Low Lube Oil Level - Will cause immediate shutdown as well as inhibit starting when active.

12. Battery Charger Fail - When active displays a warning.

13. Low Coolant Level - Will cause immediate shutdown as well as inhibit starting when active.

14. Emergency Stop N/O - Grounding this input will cause an immediate shutdown and lockout with a message of "Emergency Stop". System will not start until this is cleared.

15. Emergency Stop N/C - Removing ground from this input causes an immediate shutdown and lockout with a message of "Emergency Stop". System will not start until this is cleared.

16. Oil Filter Restriction - When active, gives an oil filter flow is restricted warning.

17 - 22. Gen Config 1 - 6 - Used to set up the parameters for reconnectable gensets. There are 6 genset profiles. If no profiles are selected, the controller will show profile #1 by default. If more than one are selected the controller will show profile #1.

23 - 31. User 1 - 24 - There are up to 24 user-defined digital-inputs. Each can have a user defined label that is displayed when active, and action that occurs when active. (Set up for these inputs is done with the iGCON software tool).

32. Remote Auto/Manual Select - When Auto is active, it causes the unit to go into automatic mode. When Manual is active, it causes the unit to go into manual mode.

33. Idle Engine - When active, it disables all shutdown faults except Overspeed/Over frequency.

34. Remote Up Key - Functions the same as the front panel key, except using a digital input.

35. Remote Down Key - Functions the same as the front panel key, except using a digital input.

36. Remote Left Key - Functions the same as the front panel key, except using a digital input.

37. Remote Right Key - Functions the same as the front panel key, except using a digital input.

38. Run To Destruct - When enabled (There is a hardware trace that must be cut to enable this!) this causes the controller to ignore all shutdowns and continue to operate no matter what. This is also sometimes called a “Battle Short” input.

39. Modbus Mode change OK - When using the Modbus server (slave) port, this allows a remote user to change from AUTO to MANUAL and vice versa if it is active.

40. Disable Keyboard - When this input is active the front keyboard is totally locked out.

Generator Steering

In applications where there is a voltage reconnection switch for reconfiguring the alternator from 480V 3 phase 4 wire to 240V 3phase 4 wire or 240V single phase 3 wire, the steering inputs allow a means to track which configuration is currently selected. This is done by means of selecting (grounding) the appropriate input via an auxiliary contact on the reconnection switch. There are up to 6 selections available from the iGUARD controller. Each is fully independent (except for the CT selection) from the others. Some 480/240V reconnectable applications look like this schematic:

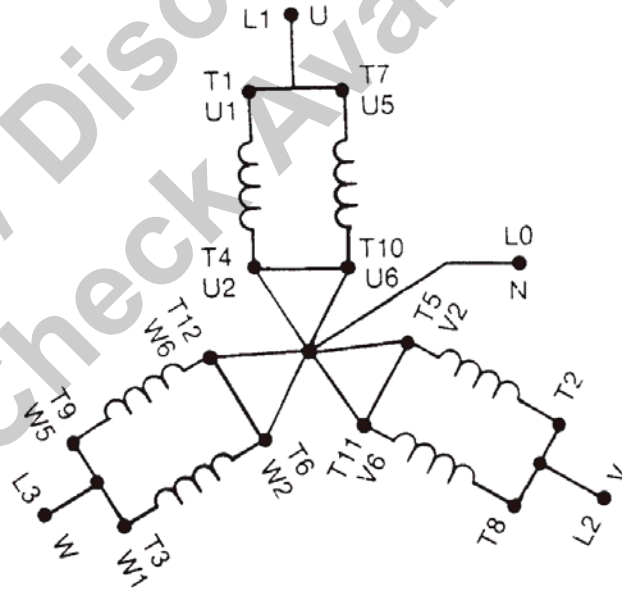

With the CT positioned on the coil winding just prior to the electrical connection of T7/T1, T8/T2, and T9/T3 and voltage connections tied to the top of T7, T8, & T9 in both the high and low voltage positions.

The low wye will read full output voltage (L-N) and half of the current (per phase). The high wye will read half of the output voltage (L-N) and full current (per phase).

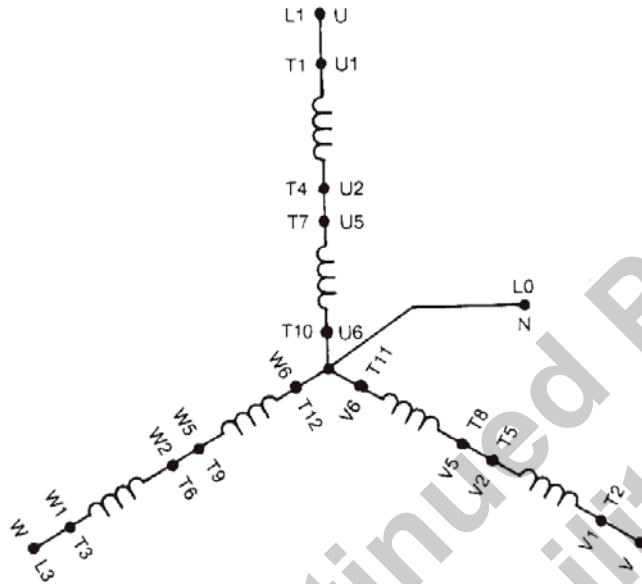

The CT's have to be sized to read the current in the high wye configuration (The current through a conductor is identical throughout the conductor) – A series connection adds voltage but not current, and the low wye configuration.

A lot of confusion occurs because switching from windings in parallel to windings in series (and vice versa) basically means that the measurement points always see exactly the same current and voltage, but the “output” current and voltage differ.

The simplest way to keep track of this is to remember that in series – The output voltages add but currents remain the same, while in parallel, output currents add but the voltages remain the same.

For example, assume that we are in a high wye configuration. If we are loaded such that the coil T7-T10, T8-T11, and T9-T12 are all producing 50A, the measurement points will read nominal 240V and 50 A, but the output connections as measured at T1, T2, & T3 will read 480V but still be 50 A - In a high wye the voltages add but the series coil currents remain the same.

Now assume a low wye - If we are loaded such that the coil T7-T10, T8-T11, and T9-T12 are all producing 50A, the measurement points will read nominal 240V and 50 A, but the output connections as measured at T1, T2, & T3 will read 240V and the output current will be 100 A - In a parallel connection the voltages stay the same, but the currents add.

In either case, note that at the measurement point the voltage is always 240V, and the measured current is always 50A.

A more easily understood method is to connect the iGUARD to the output terminals, with the CTs sized for maximum current in the low wye configuration. This way, the controller can read what is actually coming out of the generator, without any need to interpolate and assume. This will offer increased accuracy, and is generally easier to understand.

Output Parameters

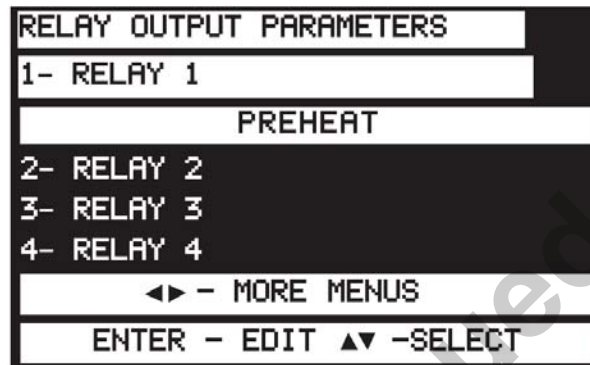

1. Relay 1 - Preheat.
2. Relay 2 - Crank.
3. Relay 3 - Fuel.
4. Relay 4 - Common Alarm.
5. Relay 5 - Common Alarm.
6. Relay 6 - Remote Alarm.
7. Relay 7 - Enable ECU.
8. Relay 8 - Not in Auto.

Output States

1. Not Used.
2. Preheat - Relay follows the selected preheat state.
3. Crank - Relay follows the crank setting.
4. Fuel - Relay operates as "Energized to run" suitable for fuel control.
5. Shutdown Lockout - Relay is active when system has shutdown on a fault and is energized until reset.
6. At Load Contactor - Relay closes when controller goes to "AT LOAD".

- 7. Shutdown** - Activated only by a fault shutdown.
- 8. Common Alarm** - Any warning or shutdown condition will activate the relay.
- 9. Remote Alarm** - Any alarm condition will actuate this output; can be de-energized by an ACK or by a reset condition.
- 10. Air Damper N/De-energized** - Relay operates when system goes into overspeed or if emergency shutdown is active.
- 11. Not in Auto** - Relay operates when system is not in auto mode - Self-clearing. .
- 12. Low Oil Pressure Warning**- Relay operates when the engine oil pressure is below the warning setpoint - self-clearing.
- 13. Low Oil Pressure Shutdown** - Relay operates when the engine oil pressure is below the warning setpoint - requires reset to clear.
- 14. Low Eng. Temp.** - Relay operates when the low coolant temperature is below the setpoint - Self-clearing. Coolant temperature is below the setpoint - Self-clearing.
- 15. High Eng. Temp. Warning** - Relay operates when the engine coolant temperature is above the warning setpoint - self-clearing.
- 16. High Eng. Temp. Shutdown** - Relay operates when the engine coolant temperature is above the shutdown setpoint - Requires Reset to clear.
- 17. Over-Speed** - Relay operates when engine speed exceeds the setpoint - Requires Reset to clear.
- 18. Over Frequency** - Relay operates when AC frequency exceeds the setpoint - Requires Reset to clear.
- 19. Under Speed** - Relay operates when the engine RPM falls below the setpoint - self-clearing.
- 20. Under Frequency** - Relay operates when the AC frequency falls below the setpoint - self-clearing.
- 21. Low Battery** - Relay operates when steady state DC voltage falls below the setpoint - Self-clearing.
- 22. Weak Battery** - Relay operates when DC voltage during the crank cycle falls below the setpoint - ACK or reset to clear.
- 23. High Battery** - Relay operates when steady state DC voltage rises above the setpoint - Self-clearing.

24. Low AC Voltage - Relay operates when AC voltage falls below the setpoint - ACK or reset to clear.

25. High AC Voltage - Relay operates when AC voltage rises above the setpoint - ACK or reset to clear.

26. Over Current - Relay operates when AC current rises above the setpoint - ACK or reset to clear.

27. PF Out of Range - Relay operates when the power factor is less than the setpoint.

28. kW Limit - Relay operates when the calculated kW is greater than the setpoint - ACK or reset to clear.

29. Remote Contact 1 - 3 - When remote communications have been established, the remote user can remotely actuate/deactuate the relays. Relays maintain their state until either the remote user changes them again or the unit is reset.

30. Digital Input 1 - 24 - relays follow the input state of the respective digital input.

31. ECU Enable - Relay operates to enable the engine ECU. ECU enable will open during STANDBY.

32. Prelube / Post Lube - Relay operates to activate for both, pre and post lube cycles.

33. Prelube - Relay operates to activate prelube cycle.

34. Post Lube - Relay operates to activate postlube cycle.

35. Prestart Delay - Delay to prevent nuisance starts or to give warning when equipment is about to run.

36. Oil Level Low Warning - Relay operates when low oil level input active.

37. Coolant Level Low Warning - Relay operates when low coolant level input active.

38. Excite Engine Alternator - Relay output to activate engine alternator excitation.

39. Engine Running No Load - Relay output active when engine running without load.

40. Idle Engine - Relay active when idle engine digital input active.

41. Crank Retries Exceeded - Engine did not start within programmed number of tries. (Also called 'overcrank')

42. Fuel N/C - Inverted logic from normal fuel relay operation

43. Running Warmup

- 44. Running Cooldown
- 45. Air Damper N/Energized
- 46. Run to Destruct Enabled
- 47. Energized to Stop - Relay turns ON at shutdown and stays on for length of ETS timer.
- 48. Engine running - Engine speed is above crank disconnect speed
- 49. Battery Charger Fail
- 50. Oil Temp. High - Oil temperature is above warning setpoint.
- 51. Fuel Level Low Warning
- 52. Modem Power Enable - Used to turn modem on/off to force a known state
- 53. Running Warm-up and Cool-down - Reply turns on in both warm-up and cool-down
- 54. Not in Standby/Aux. Device
- 55. IDMT Warning (above pickup current)
- 56. IDMT Shutdown
- 57. Shunt Trip Alarm

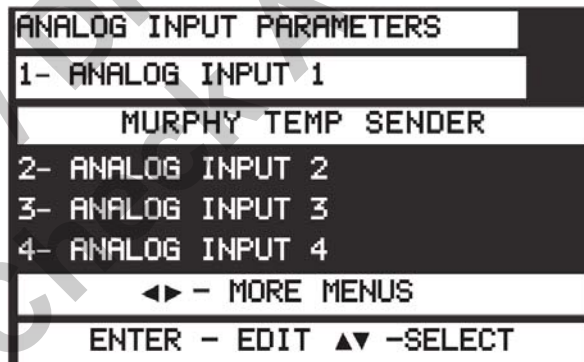

Analog Inputs

There are 7 analog inputs. The first four analog inputs can be used with both resistive senders as well as 0-5VDC & 4-20mA devices, and the last three analog inputs are configured in such way that they may only be used with 4-20mA or 0-5VDC type signals.

The iGUARD uses variable precision current sources to accommodate many different brands of resistive senders as well as true detection of open/missing sender and sender shorted to ground.

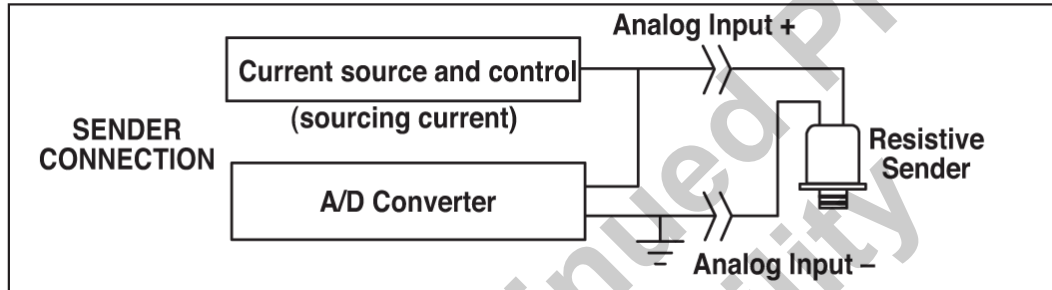

To use an analog input with a resistive sender, wire as follows:

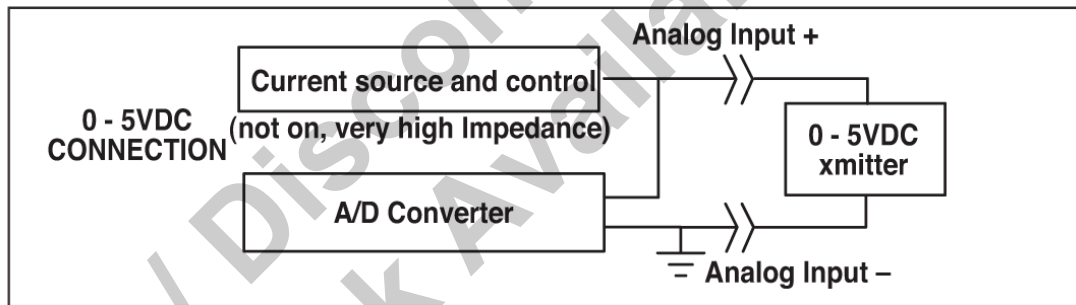

To use an analog input with a 0-5 VDC signal source, wire as follows: To use an analog input with a 4-20mA signal source and the built in 250 Ω load resistor, wire as follows:

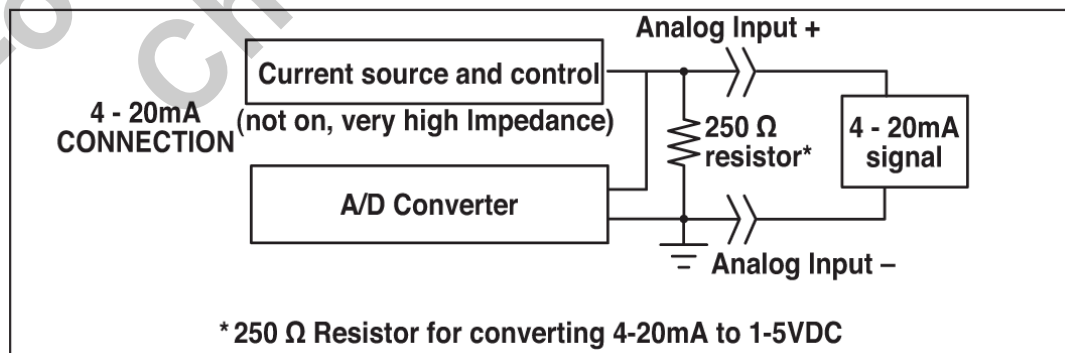

Menu Selection for Analog Inputs

1	Disabled	15	VDO 7 Bar Oil Sender
2	4 - 20mA Oil Sender	16	VDO 5 Bar Oil Sender
3	0 - 5 VDC Oil Sender	17	Datcon Temp
4	4 - 20mA Temp Sender	18	Murphy Temp
5	0 - 5 VDC Temp Sender	19	VDO A Temp
6	4 - 20mA Fuel Sender	20	VDO B Temp
7	0 - 5 VDC Fuel Sender	21	BMI Temp
8	4 - 20mA Oil temperature	22	Datcon Fuel
9	0 - 5VDC Oil Temperature	23	Murphy Fuel
10	0 - 5VDC VDO Temp special (Optional output board Required)	24	VDO Fuel
11	0 - 5VDC VDO Pressure special (Optional output board Required)	25	Datcon Oil Temp
12	0 - 5VDC current	26	Murphy Oil Temp
13	Datcon Oil Sender	27	VDO A Oil Temp
14	Murphy Oil Sender	28	BMI Oil Temp

Clock Start/Stop Parameters

1. Press Enter to display the first start day and time screen. The default is OFF.
2. Press the Right and Left arrows to select a day of the week
3. Press the UP and DOWN arrows to select a time.
4. Press Enter to save.

5. Use the Down Arrow to move to the First Stop day and time screen. The default is OFF. Press the Right and Left arrows to select a day of the week.

6. Press the UP and DOWN arrows to select a time.

7. Press Enter to save. Repeat for start/stop times 2 and 3 if needed.

Alternate Signal Polarities for the Digital Inputs

Most applications will require that ground be applied as the signal that an input is active. The standard iGUARD connection diagrams show this type of connection. However, some applications either require or are much easier to implement using a positive +V battery signal to indicate the input is active.

		J5		
Digital input 1 return and polarity select	9	1		Digital Input 1
No Connection	10	2		Digital Input 2
No Connection	11	3		Digital Input 3
No Connection	12	4		Digital Input 4
No Connection	13	5		Digital Input 5
No Connection	14	6		Digital Input 6
No Connection	15	7		Digital Input 7
No Connection	16	8		Digital Input 8

If terminal 9 is tied to the +V battery, applying ground to terminal 1 will activate the input (DEFAULT METHOD). If terminal 9 is tied to ground, applying +V battery to terminal 1 will activate the input.

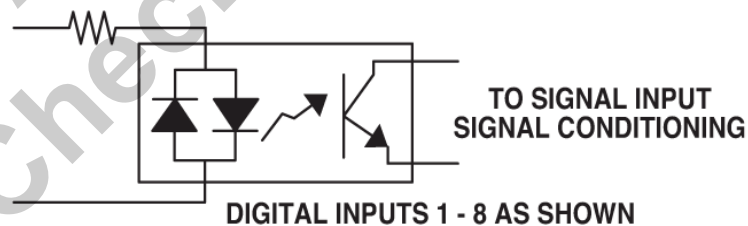

Inputs 9 - 24 are ganged together. They have a common that may be tied high to give 'ground active' operation, or tied to ground to give '+V Battery active' operation.

		J6			
Digital Input 9-24 Common	10	1	10	1	Digital Input 9-24 Common
Digital Input 17	11	2	11	2	Digital Input 9
Digital Input 18	12	3	12	3	Digital Input 10
Digital Input 19	13	4	13	4	Digital Input 11
Digital Input 20	14	5	14	5	Digital Input 12
Digital Input 21	15	6	15	6	Digital Input 13
Digital Input 22	16	7	16	7	Digital Input 14
Digital Input 23	17	8	17	8	Digital Input 15
Digital Input 24	18	9	18	9	Digital Input 16

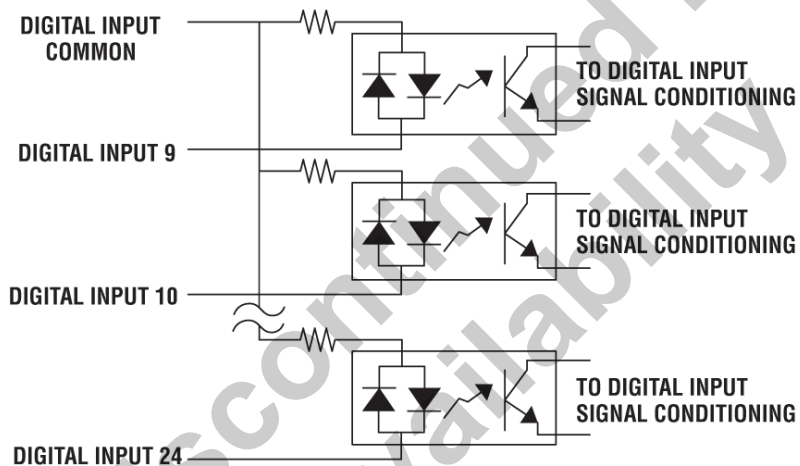

Relay Functions Display

All relay functions that are active will be displayed on the screen. If a relay has been assigned a function that is currently active, then that relay number will appear to the left of the active relay function name.

Relay designation is displayed in sequence. For the first remote relay board, the relay designation will be assigned in sequence starting at 101 up to 124 (example, Relay 1 is displayed as 101, Relay 2 is displayed as 102 , etc.).

For the second remote relay board, the relay designation starts at 201 up to 224 (example, Relay 1 is displayed as 201, Relay 2 is displayed as 202, etc.).

Using iGUARD with ECU Controller Engines

In most Tier 2 compliant engines, the manufacturers have elected to move to electronic controls to meet the exhaust emissions requirements mandated by the various air quality boards. These controls allow for very precise control of the engine to limit emissions to the legal level or below. One side effect is that there no need for the user to supply any senders when using the iGUARD with a J1939 Engine Control Unit or Electronic Control Unit (ECU) equipped engine, and that there is a large amount of useful data available from the engine ECU.

In genset applications, the simplest implementation is to treat the engine ECU like a fuel solenoid in a non-ECU equipped engine.

When there is a call to run:

1. The iGUARD closes the ECU enable relay, applying power or logic enable to the ECU.
2. The iGUARD waits a short time for the ECU to power up and stabilize.
3. The iGUARD communicates with the ECU to see if there are any "Wait to start" conditions, such as:
 - a. Important variables not at their "ready to start values".
 - b. The ECU is sending out a Wait-to-Start message.
4. If there are no "Wait to start" conditions, the iGUARD begins a normal start cycle, or if there are one or more "Wait to Start" signals, the iGUARD waits for them to clear before proceeding.

To use the iGUARD controller with an ECU equipped engine you must make the following selections in the programming stacks:

In the miscellaneous parameters stack:

- Select the type of ECU (J1939).
- Select the manufacturer of the engine/ECU.

In the relay programming stack:

- Program a relay for "ECU enable". (relay 7 is default)

On SAE-J1939 equipped engines, the data connection will read any available status messages, and if there is a wait to start message, the iGUARD will delay cranking until the engine ECU clears that message.

The ECU broadcasts the data over the J1939 data connection and the iGUARD uses the following parameters to operate:

- Oil pressure
- Coolant temperature

- Engine RPM
- Battery voltage
- Hours

Plus a number of status bits - such as wait to start, and the lamp codes (Shutdown, warning, maintenance).

The iGUARD displays active fault codes*. Additionally, the engine faults and severity for the most common faults and warnings are displayed not only as the Suspect Parameter Number, (SPN) and failure mode indication (FMI) but also in plain text.

This is intended to help with any troubleshooting.

The numeric fault codes are always available, in case the fault or warning message is not one of the ones supported by text description.

The iGUARD will show messages in the Warnings/faults status screen. There is a J1939 screen that shows specific J1939 fault codes, status of the indicator lamps etc. This screen only shows up when the iGUARD is set up to run from ECU data.

■ Note: * Applicable if the ECU manufacturer supports Active Fault

Manufacturers Specifics

As of May, 2003 here are known manufacturers wiring guides and some peculiarities associated with each manufacturer:

Detroit Diesel DDEC IV ECU

- Install any/all ECU connections as per the DDEC manual.
- Program relay 7 on the iGUARD to be "ECU enable"
- Run a wire from the common of relay 7 to +V battery
- Run a wire from relay 7, normally open terminal to the DDEC IV wire 439.

Notes: DDEC systems prior to December 2002 did not broadcast DM2 (stored) fault codes.

DDEC II systems are not SAE-J1939 equipped.

Detroit engines having more than 8 cylinders use multiple ECU's in a master/slave relationship. This will require that the address claim selection be enabled in the J1939 setup screen.

John Deere ECU

- Install any/all ECU connections as per your ECU manual.
- Program relay 7 on the iGUARD to be "ECU enable"
- Run a wire from the common of relay 7 to +V battery
- Run a wire from the normally open contact of relay 7 to terminal G on the 21-pin instrument panel connector.

Notes: John Deere originally implemented J1939 revision 2. When finalized, it implemented revision 4 of the standard. As long as the iGUARD is set to "DEERE" as a manufacturer, we can determine the ECU software revision and automatically accommodate for this version.

Volvo PENTA series ECU

- Install any/all ECU connections as per your ECU manual.
- Program relay 7 on the iGUARD to be "ECU enable"
- Run a wire from the common of relay 7 to +V battery
- Run a wire from the relay 7, normally open contact to the ECU terminal P.

Notes: Volvo PENTA does not appear to claim / allow claim of addresses on the J1939 databus. The iGUARD will automatically accommodate this when the iGUARD is set to "VOLVO" as the engine manufacturer. Recent ECU software upgrades for load sharing and synchronization require additional connections to the ECU - See the data supplied with the engine.

The Volvo ECU also supports crank control directly from the ECU. This further simplifies connecting the iGUARD to the Volvo ECU.

Caterpillar ECU

- Install any/all ECU connections as per your ECU manual.
- Program relay 7 on the iGUARD to be "ECU enable"
- Run a wire from the common of relay 7 to +V battery
- Run a wire from the normally open contact of relay 7 to pin 26 of the 40 pin connector on the ADEM 3 ECU

Notes: The ADEM 3 ECU constantly broadcasts DM1 message "No error". Make sure that the manufacturer is set to "Caterpillar" to accommodate this.

Deutz ECU

- Install any/all ECU connections as per your ECU manual.
- Program relay 7 on the iGUARD to be "ECU enable"
- Run a wire from the common of relay 7 to +V battery
- Run a wire from the normally open contact of relay 7 to pin 14 on the 25-pin EMR connector

Cummins QS series ECU

- Install any/all ECU connections as per your ECU manual.
- Program relay 7 on the iGUARD to be "ECU enable"
- Run a wire from the common of relay 7 to +V battery
- Run a wire from the normally open contact of relay 7 to:
 - Cummins QSM/QSX series: pin 38 on the 50-pin OEM connector
 - Cummins QSK-19 series: pin 01 on the 31-pin OEM connector
 - Cummins QSB/QSC series: pin A on the 23-pin OEM connector (engine access connector)
 - Cummins QST-30 series: pin A on the 21-pin OEM connector

Notes: The Cummins G-Drive controllers (Except for the G-drive version of QSM) are not currently J1939 enabled. The existing G-Drives are MODbus protocol RS-485 connection, and are not currently (May 2003) supported by the iGUARD. This support will eventually be added in the planned phase two firmware release. Contact the factory (918) 317-4100 about availability.

iGUARD Typical Installation and Mounting

Mechanical Installation and Mounting

Please make sure that the controller was not subjected to abusive handling during shipping and that all the components are included.

You should receive the iGUARD controller, any accessories ordered such as wire harnesses, CT's, PT's, senders, and this document.

The iGUARD controller is designed to be mounted within a customer-supplied panel. It can also be installed in an optional set-top control box, or in the 'doghouse' of an AC alternator.

When the iGUARD is used as a standalone device, it must be mounted within a protective housing. Refer to the cutout schematic (below) for layout of the cutout and mounting screw holes.

Once the holes are cut, check to make sure that there is adequate clearance - so that the edges of the iGUARD housing mounts flat and flush against the outside surface of your enclosure.

IMPORTANT

Be sure to check that there are no loose metal shavings, or other conductive debris that may fall into or get blown into the circuit boards of the iGUARD.

Recommended torque for tightening the mounting screws is 9-inch pounds. Only Polycarbonate compatible thread lock should be used for the iGUARD mounting screws.

Insert the iGUARD controller from the front side of the panel and install the four mounting screws and lock washers. Ensure that there is a good seal between the controller, the "O" ring and the mounting panel. Plan the iGUARD mounting for easy wiring and access.

iGUARD Dimensions and Cutout Schematic

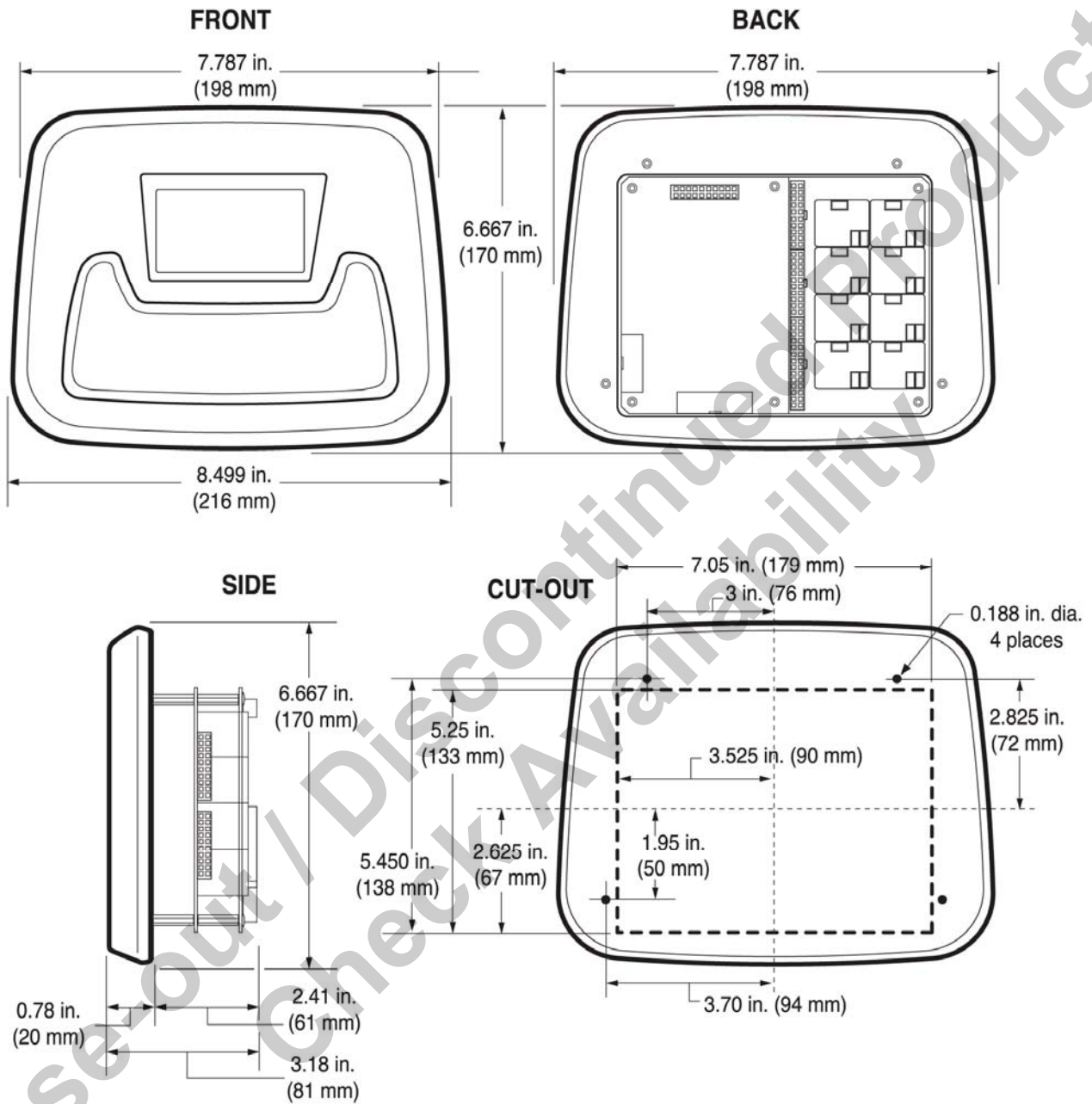

iGUARD Typical Connector Layout

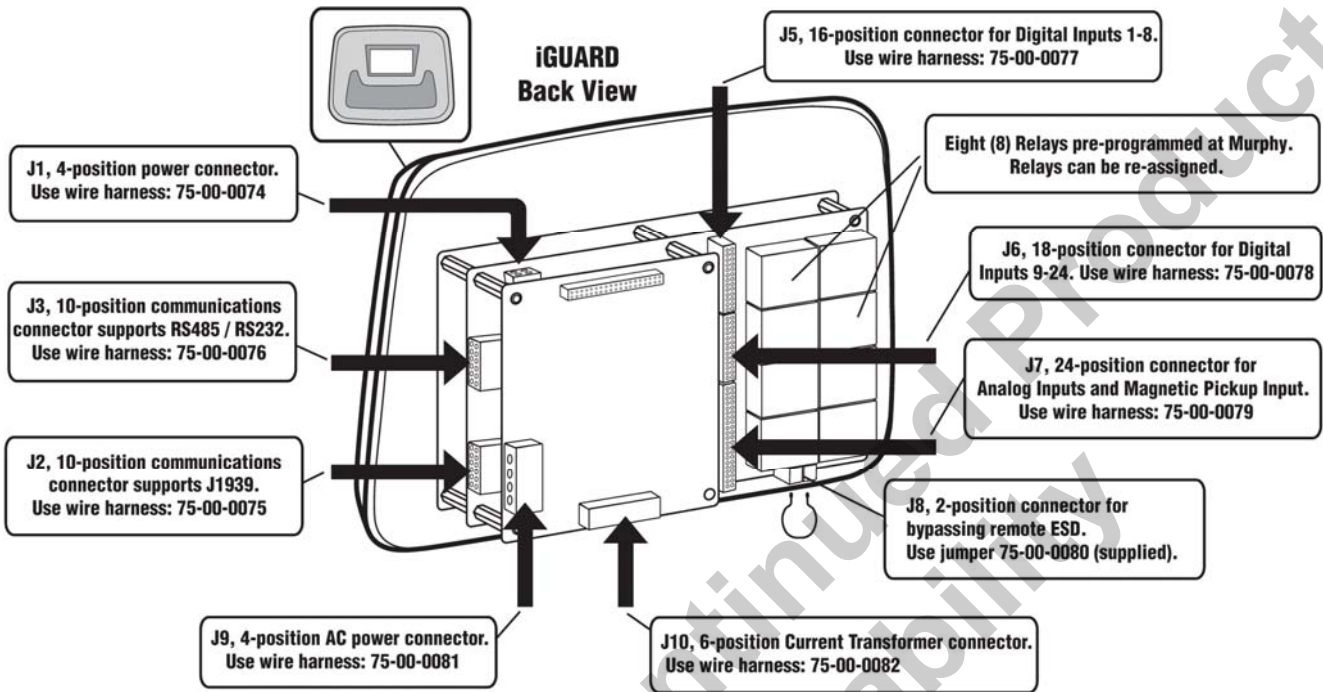

iGUARD Typical Components

The iGUARD Controller Components

1. Bezel / Faceplate
2. O-Ring
3. User Interface Board
4. I / O Board
5. Energy Monitoring Board
6. Cover
7. Standoffs

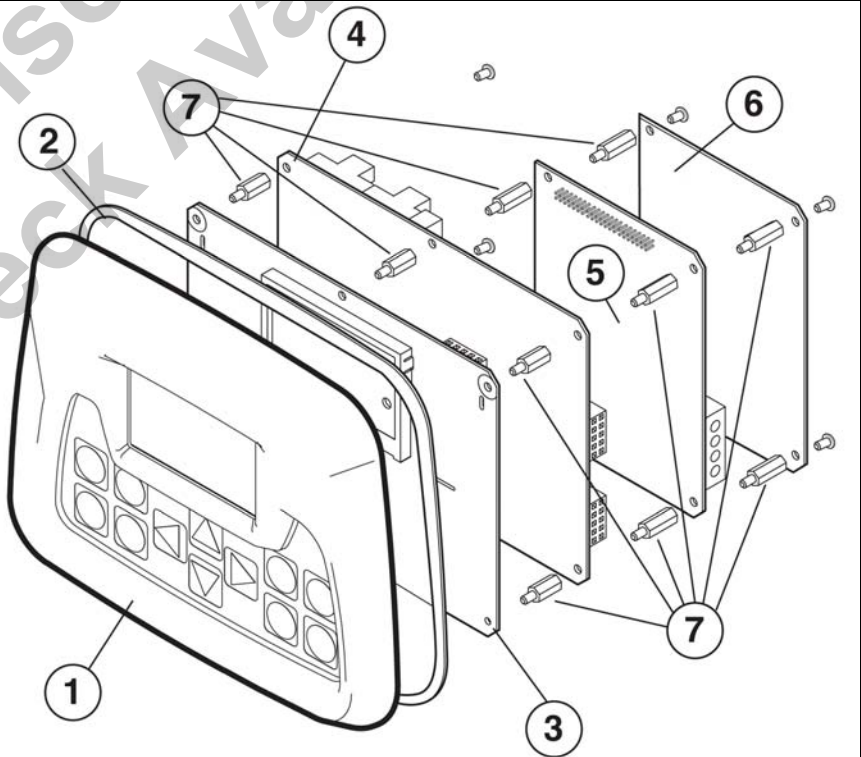

iGUARD Electrical Installation

Electrical Hook up

There are several wire harnesses or wire harness plug-in connectors that may be shipped with the controller.

- **Two (2), 10-position connector:** for J1939, RS485 / RS232
- **One (1), 16-position connector:** for Digital Inputs
- **One (1), 18-position connector:** for Digital Inputs
- **One (1), 24-position connector:** for Analog Inputs
- **One (1), 6-position connector:** for Current Transformer Inputs
- **One (1), 4-position connector:** for AC Voltage and Neutral Inputs
- **One (1), 4-position connector:** for DC supply

Additionally there is a 2-position connector for normally closed Emergency Shutdown switch that is shipped installed on the controller. There are three (3), 1/4" blade-type push-on terminals for each of the eight (8) form-C-relays. They are Normally Open, Normally Closed, and Common. These contact outputs are dry. The dual row white connectors are all intended for low voltage.

J1 – Power Connector

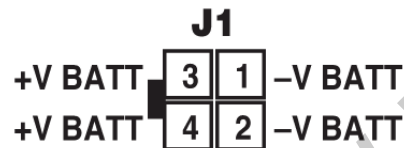

J2 – Communications Connector

This communications connector supports J1939 and Modbus server (slave).

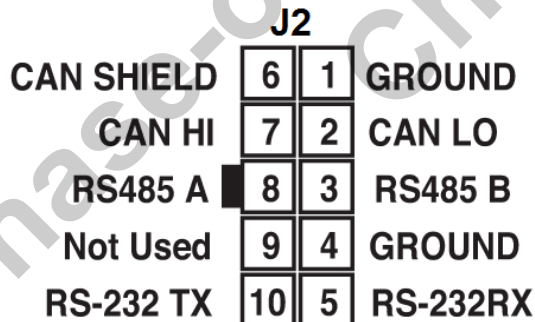

J3 – Communications Connector

This communications connector supports RS-232 for programming the controller with the iGCON software tool, modem connection and the Modbus client (master) connection

J3		
Not Used	6	1 GROUND
Not Used	7	2 Not Used
RS485 A	8	3 RS485 B
Not Used	9	4 GROUND
RS-232 TX	10	5 RS-232RX

J5 – Digital Inputs 1 - 8

J5		
DIGITAL INPUT 1-8 (TIE TO +V)	9	1 AUX OVERSPEED
	10	2 AUX CRANK CUT
	11	3 USER INPUT 1
	12	4 USER INPUT 2
	13	5 USER INPUT 3
	14	6 USER INPUT 4
	15	7 USER INPUT 5
	16	8 USER INPUT 6

J6 – Digital Inputs 9 – 24

Signals for the digital inputs 1-24 must be in the in the range of +V battery and ground. With the inputs wired as show (this is the default), they will be active when there is a ground applied to the respective input. They can be connected to be active when +V battery is applied, but the connections are different. See Alternate Signal Polarities for the Digital Inputs in the Analog Inputs section, in this document.

J6	
TIE TO +V BATTERY	10 1 TIE TO +V BATTERY
GENERATOR STEERING 1	11 2 REMOTE START (transfer switch)
GENERATOR STEERING 2	12 3 LOW LUBE OIL LEVEL
GENERATOR STEERING 3	13 4 LOW COOLANT LEVEL
GENERATOR STEERING 4	14 5 LOW FUEL LEVEL WARNING
GENERATOR STEERING 5	15 6 FUEL LEAK
GENERATOR STEERING 6	16 7 BATTERY CHARGER FAIL
FUEL FILTER RESTRICTION	17 8 E-STOP (N.O.)
AIR FILTER RESTRICTION	18 9 AIR DAMPENER CLOSED

J7 – Analog Inputs and Magnetic Pickup Input

The J7 connector is for analog inputs and the magnetic pickup input. The first 4 analog inputs have current sources for driving standard resistive senders. For best accuracy, and most noise immunity, senders should be of the two-wire type, with the return wire coming back to the appropriate sender ground.

NOTE: Murphy recommends the use of two wire senders, with the sender return connected to the analog channel.

If single ended senders are used, with ground provided at the sender itself, there can be a number of problems that may or may not affect any given installation. Since the sender body/threads provides sender ground, the use of thread tapes and compounds may give erratic operation.

Additionally, the grounds may not be completely common between different parts of the engine, alternator, and skid because there may be ground resistance between parts of the generator caused by paint, sealing compounds, rust, debris etc., and there always exists a greatly increased chance for noise and interference to affect the controller operation.

J7

Analog 1– (ground)	13	1	Analog 1 + sender or 0-5VDC
Analog 2 + sender or 0-5VDC 250 ohm load resistor for Analog 2, jumper to J7-14 for 4-20mA	14	2	250 ohm load resistor for Analog 1, jumper to J7-1 for 4-20mA
Analog 3– (ground)	15	3	Analog 2– (ground)
Analog 3 + sender or 0-5VDC	16	4	Analog 3 + sender or 0-5VDC
Analog 4 + sender or 0-5VDC 250 ohm load resistor for Analog 4, jumper to J7-17 for 4-20mA	17	5	250 ohm load resistor for Analog 3, jumper to J7-4 for 4-20mA
Analog 4– (ground)	18	6	Analog 4– (ground)
Analog 5 – (ground)	19	7	Analog 5+ 0-5VDC
Analog 6+ 0-5VDC 250 ohm load resistor for Analog 5, jumper to J7-7 for 4-20mA	20	8	250 ohm load resistor for Analog 5, jumper to J7-7 for 4-20mA
Analog 6– (ground)	21	9	Analog 6– (ground)
Analog 7 – (ground)	22	10	Analog 7+ 0-5VDC
Magnetic Pickup (+)	23	11	250 ohm load resistor for Analog 7, jumper to J7-10 for 4-20mA
Magnetic Pickup Shield (ground)	24	12	Magnetic Pickup– (ground)

J8 – Positive Emergency Stop

J8 - is the positive emergency stop. From the factory there is a loop from terminal 1 to terminal 2. The controller will power up, but will not operate the relays without this connection. If your application requires a true positive emergency stop, we recommend that you install a normally closed type switch between terminals 1 & 2. In the event of an emergency stop, actuating the switch will remove power to the relays which will then return to their un-powered state.

NOTE: Be aware that the iGCON software tool cannot update the operating firmware unless the J8 jumper is either open or removed

J8

NC EMERGENCY SHUTDOWN OUT

2	1
---	---

 N/C EMERGENCY SHUTDOWN IN

I/O Board Relays

The 8 relays mounted on the I/O board are pre-programmed at the factory to:

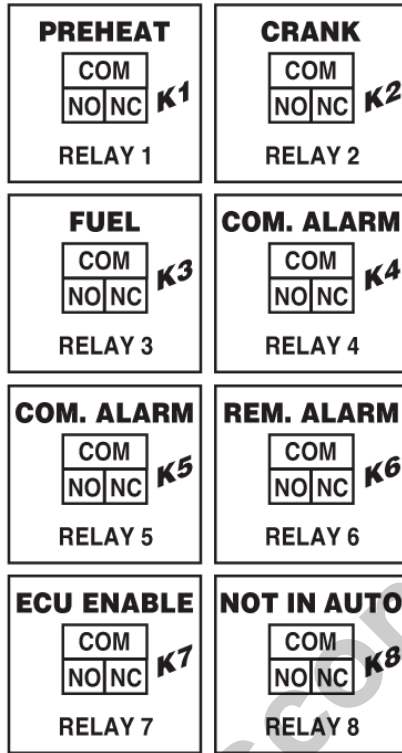

Relays may be re-assigned to any of the other desired functions at will from the front panel.

Energy Monitoring Board (EMB)

From the rear of the unit, there is a smaller board on the left side. This is the energy monitoring board. All the AC connections are made here. It has two single row black connectors labeled J9 & J10.

J9 – AC Voltage Connections

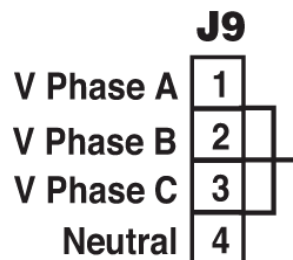

In 3-phase applications apply:

- phase A to terminal 1
- phase B to terminal 2
- phase C to terminal 3
- neutral to terminal 1

In single phase applications apply:

- phase A to terminal 1
- phase B to terminal 2
- neutral to terminal 4

In Center Tapped Delta applications, apply:

- phase A to terminal 1
- phase B to terminal 2
- phase C to terminal 3
- neutral to terminal 1

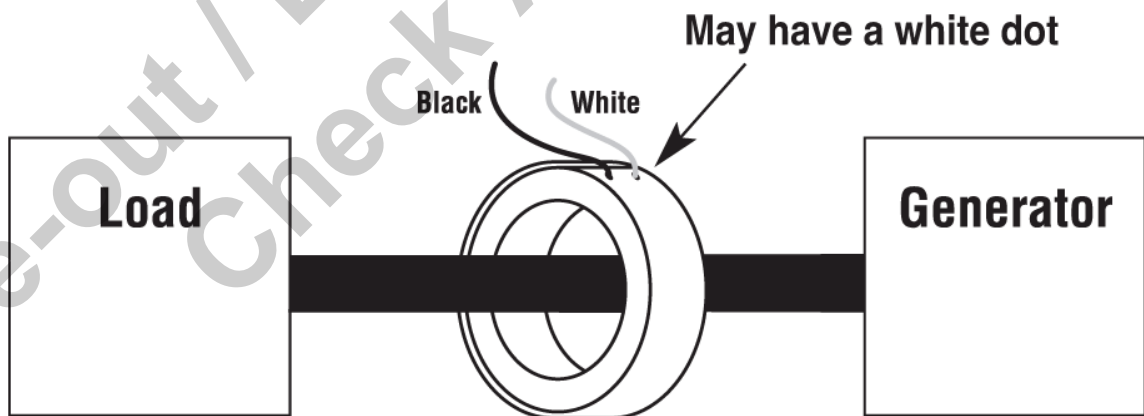

J10 – Connections from the CT's

J10	
Current Transformer +, Phase A	1
Current Transformer -, Phase A	2
Current Transformer +, Phase B	3
Current Transformer -, Phase B	4
Current Transformer +, Phase C	5
Current Transformer -, Phase C	6

The most accurate method of measuring current will be to connect each wire from each of the CT's directly to the controller at J10. The controller offers a low impedance path to neutral (~.25 Ohms) so the common mode voltage will be well within a safe range.

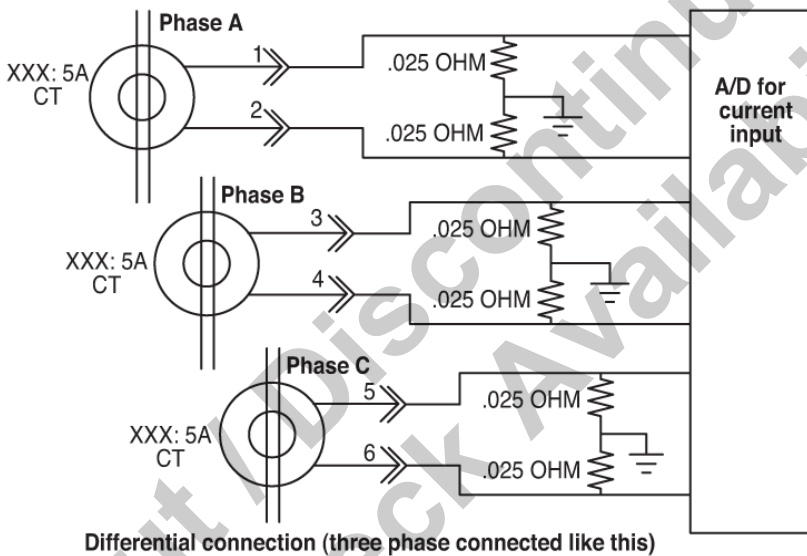

In applications where the CT's are commoned together (4 wires - CT1+, CT2 +, CT3+ and CT common) the system will only read 1/2 of the current signal, unless the iGUARD is programmed to reflect commoned CT's.

The iGUARD supports both, full differential CT inputs (both wires from each CT brought back to the EMB) and "commoned" CTs (where the high sides are brought back individually but the low sides are all connected together). See the following illustration of current input construction.

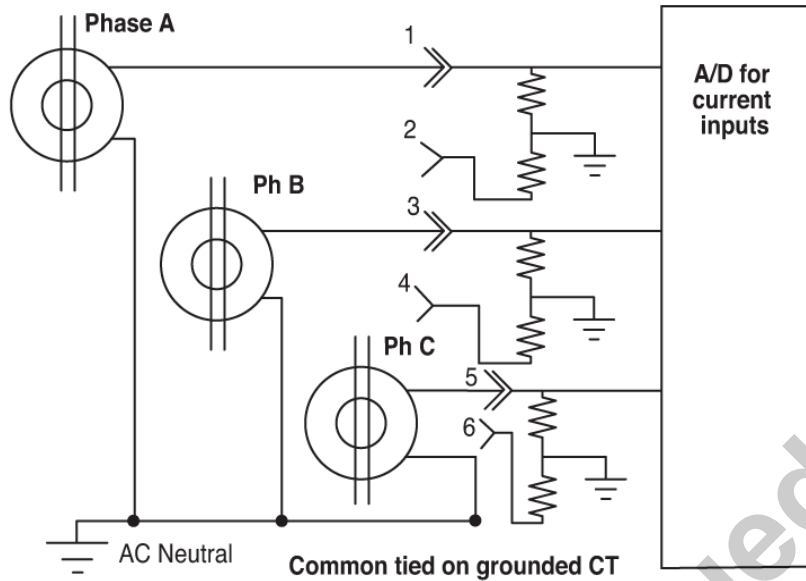

In fully differential connections, wire CT1+ to J10-1 to J10-2, etc. For commoned CT connections bring CT1+ to J10-1, CT2+ to J10-3 and CT3+ to J10-5. Connect CT1-, CT2-, and CT3- together and then connect to AC neutral. There is no need to jumper J10-2, 4 and 6 to anything, although you can connect them to AC neutral if you wish.

There is a software selection in the iGUARD that must be set appropriate to the connection method you are using. See Operating Sequence in the iGUARD Operating Instructions section in this document.

The measuring method in the iGUARD controller requires that AC neutral and earth remain with 1/2 VDC for accurate measurements, and within 6 VDC to prevent damage to the Energy monitoring board (EMB). The controller offers a low impedance path to neutral ($\sim .025 \Omega$) so the common mode voltage will be within a safe range.

Commercially Available Connectors

Connections to the iGUARD are via Molex connectors, MiniFit Jr. (for white/opaque white signal level connectors), and Sabre series (for black EMB AC voltage and current connectors). 12 foot long harnesses are available from Murphy (see “Options and Accessories” section).

If you elect to build your own wire harnesses the following information on manufacturer’s part numbers will be useful.

Connector Part Numbers

The MiniFit Jr. Series of connectors requires a crimping tool (such as a universal crimper) to properly terminate the connectors. When terminating multiple wire harnesses, contact your local Molex distributor for information on automated termination tooling.

An extractor tool might also be necessary in case of a broken wire, misinserted terminal, or when a wire needs to be removed.

Plug - Low voltage signals	Molex Part Number - plug	Molex 16 ga. crimp on terminal	Molex 18-24 ga. crimp on terminal	Digikey Part Number - plug	Digikey 16 ga. crimp on terminal	Digikey 18-24 ga. crimp on terminal	Murphy PN Plug
2 conductor	39-01-2020	39-00-0078	39-00-0039	WM3700-ND	WM1913-ND	WM2501-ND	00009457
4 conductor	39-01-2040	39-00-0078	39-00-0039	WM3701-ND	WM1913-ND	WM2501-ND	00009458
10 conductor	39-01-2100	39-00-0078	39-00-0039	WM3704-ND	WM1913-ND	WM2501-ND	00009459
16 conductor	39-01-2160	39-00-0078	39-00-0039	WM3707-ND	WM1913-ND	WM2501-ND	00009460
18 conductor	39-01-2180	39-00-0078	39-00-0039	WM3708-ND	WM1913-ND	WM2501-ND	00009461
24 conductor	39-01-2240	39-00-0078	39-00-0039	WM3711-ND	WM1913-ND	WM2501-ND	00009462

Plug - AC voltage & current	Molex Part Number - plug	Molex Crimp on terminal	Digikey Part Number - plug	Digikey Crimp on terminal	Min/max Wire gauge	Murphy PN Plug
4 conductor	44441-2004	43375-0001	WM18465-ND	WM18494-ND	14 - 18 ga.	00009463
6 conductor	44441-2006	43375-0001	WM18467-ND	WM18494-ND	14 - 18 ga.	00009464

DigiKey Part Number	WM9999-ND
Manufacturer Part Number	63811-1000
Description	Molex Universal Crimp Tool

DigiKey Part Number	WM9918-ND
Manufacturer Part Number	11-03-0044
Description	Extraction Tool Mini-Fit Jr.

DigiKey Part Number	WM9912-ND
Manufacturer Part Number	11-01-0197
Description	Crimp Tool 18-24 AWG Mini-Fit Jr.

Installing the Mimic/Annunciator DM/A

DM/A Mimic/Annunciator Versions

This covers versions 1.26 and higher. The DM/A or Mimic/Annunciator is the repeater unit for the iGUARD (Master) controller. The Mimic/Annunciator features the front bezel display which includes the user interface board and Modbus device that communications with the iGUARD (Master) controller and a wire cover. To operate the DM/A, power must be supplied to the J1 connector on the rear of the unit.

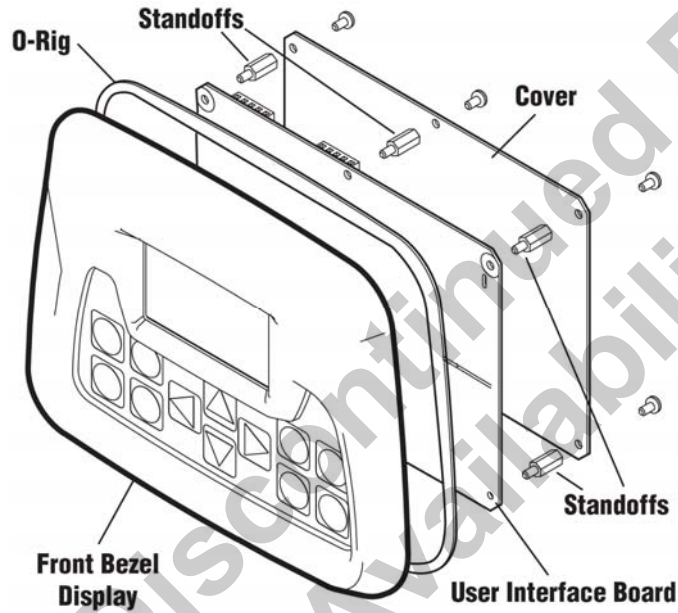

DM/A Mimic Annunciator Back View

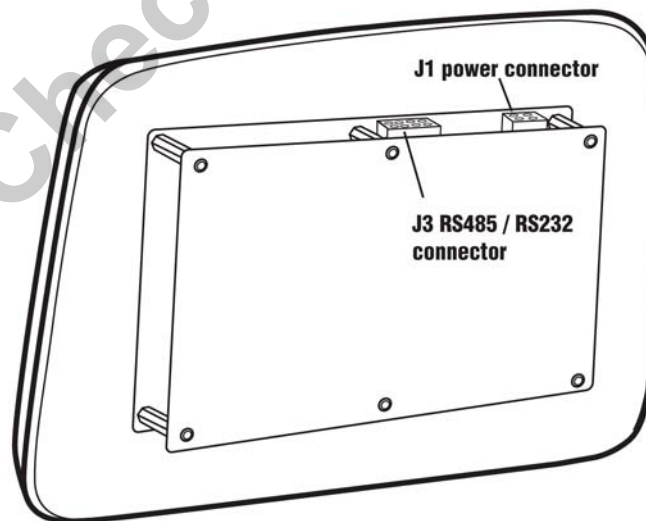

J1 Power Connector

The iGuard Mimic / Annunciator is powered using the J1 connector. The connector is wired as shown below:

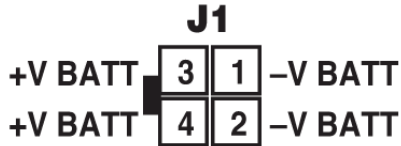

J3 Communications Connector

The iGuard Mimic / Annunciator communicates with the host iGUARD controller via a RS485 two-wire + shield connection. The connector is wired as shown below:

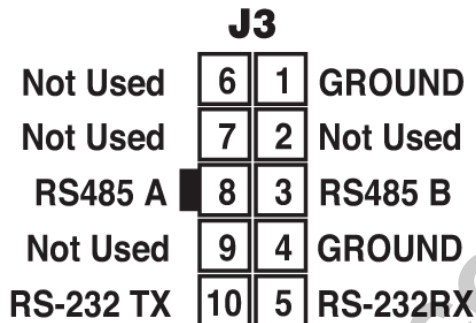

1. To configure the DM/A for a particular application do the steps as follows:
2. Press the BACK & NEXT keys at the same time.
3. The screen will change to identify the hardware/software as configured.
4. Press NEXT. The top line will display the station number.

The menus are as follows:

1. Modbus server address - This is the address of this device as seen on the network. Default is 243.

2. Key sensitivity level - This sets the required amount of force to activate the keypad. Default is Normal

3. LCD backlight - This selects whether the LCD backlight is enabled or not. If disabled, the backlight will not come on. Default is enabled

4. iGUARD beeper - This selects whether or not the station beeper is enabled. If disabled, the station will not sound any audible alarm for faults or warnings. Default is enabled.

5. Interface type - hard coded to RS485 Modbus

6. RS485 bit frame - Sets the configuration of the data transmission. Default (to match the iGUARD default) is 10 bits N-8-1.

7. RS485 baud rate - Selects the data transmission rate, and must match the rate settings on the iGUARD it is connected to. Default is 38400.

NOTE: There are corresponding settings in the iGUARD for choosing how the station operates*. The selections are "Mimic" and "Annunciator" In Mimic mode, the remote station is allowed to behave exactly as if it were the front panel of the actual iGUARD - the user may start and stop manually, change between automatic and manual modes, acknowledge alarms, and reset the system. The only thing that a mimic panel cannot do is change the programming on the master. In Annunciator mode, the station may acknowledge its own alarms and look at data, but it cannot do any control functions.

* See page 13 (21 - Repeater #1) and page 14 (22 - Repeater #2) for specifics.

iGUARD ECU Wiring

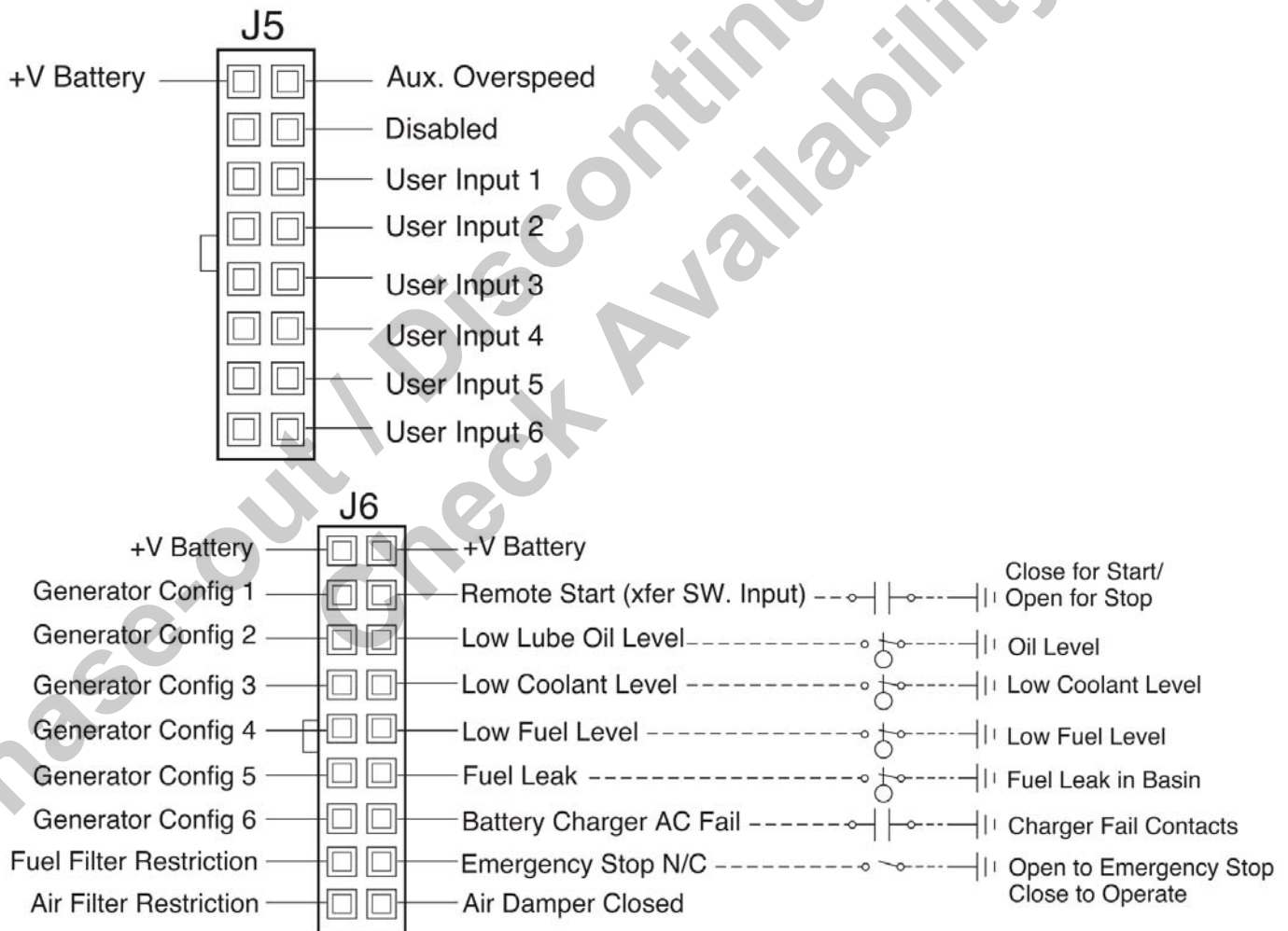

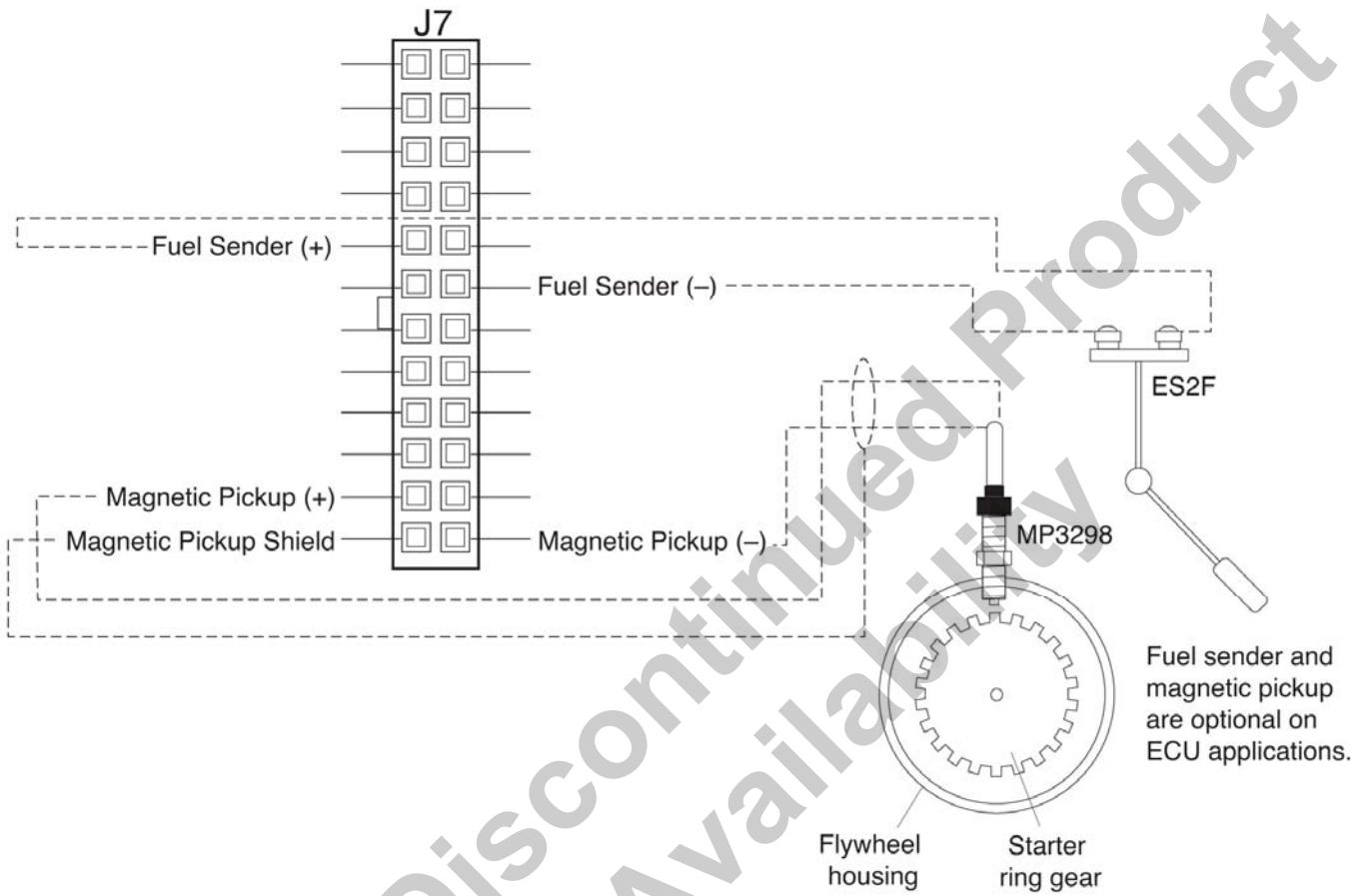

iGUARD Non-ECU Wiring

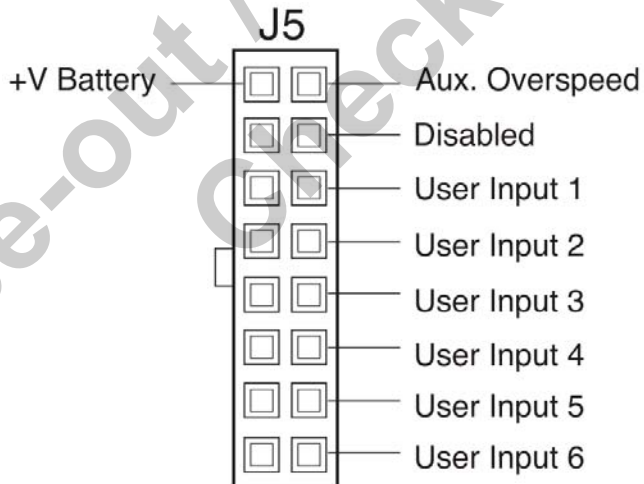

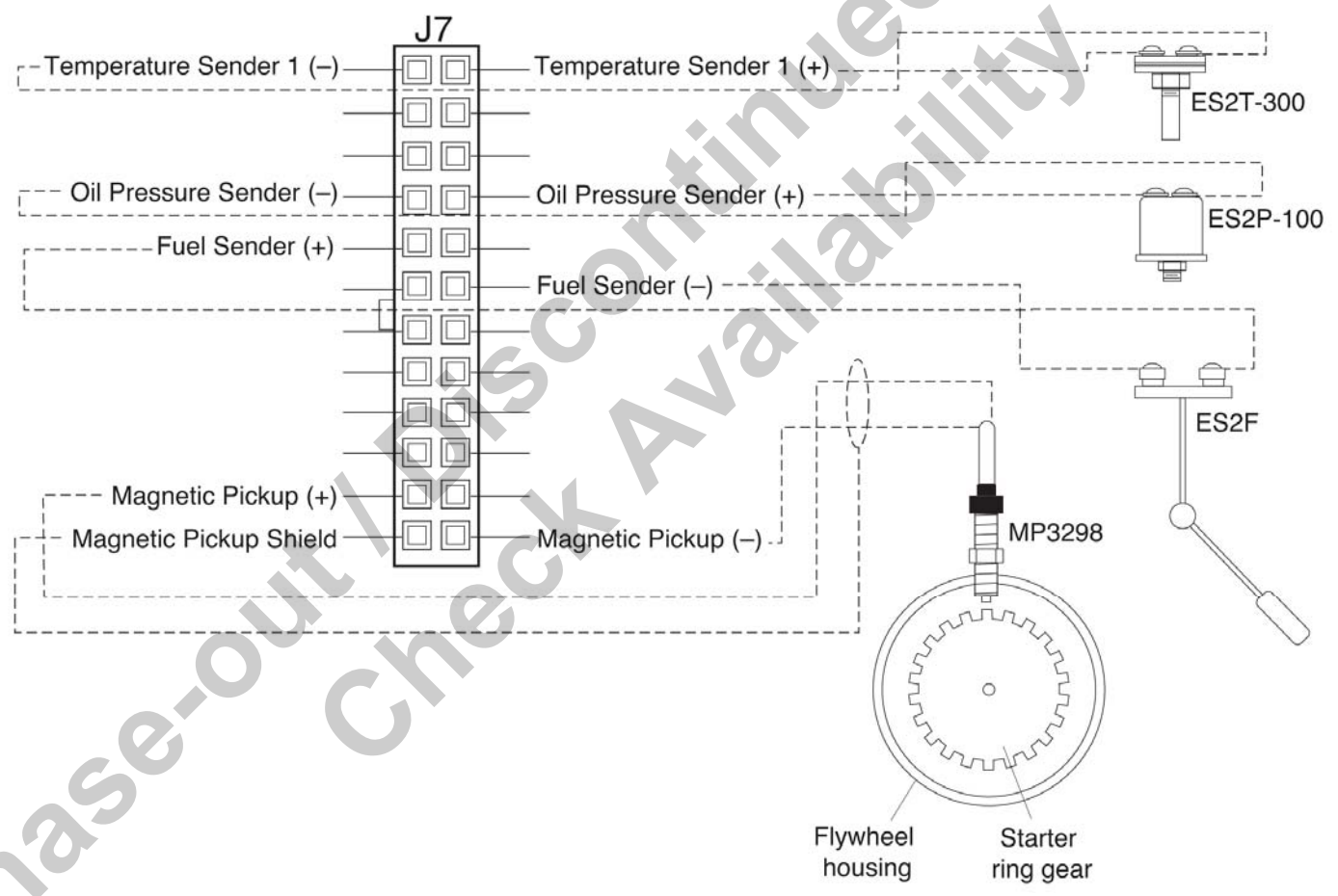
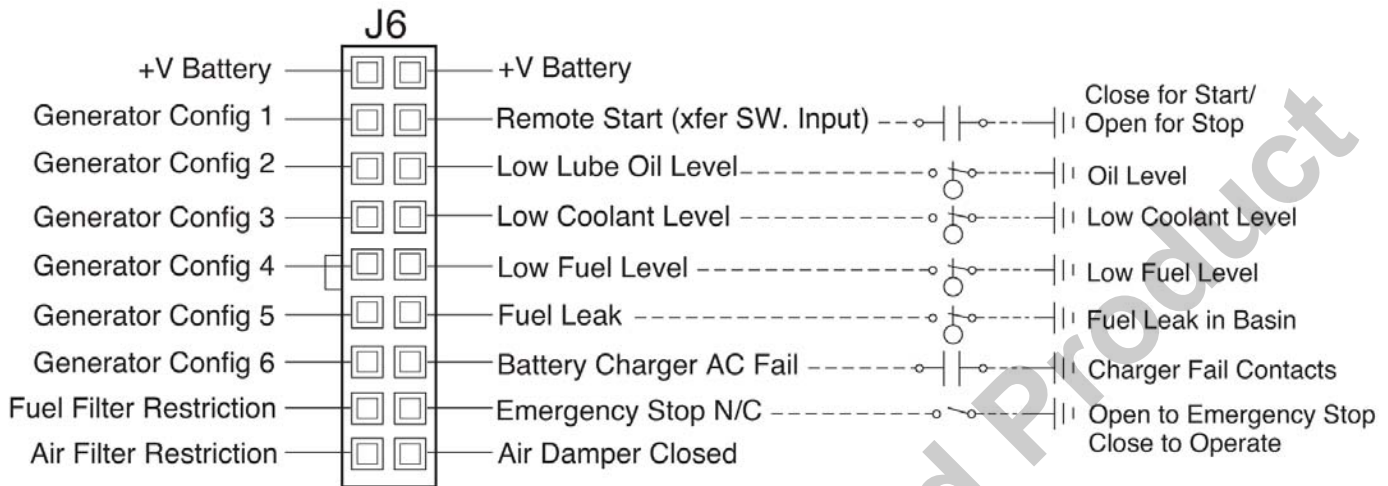

iGUARD Three Phase Wiring

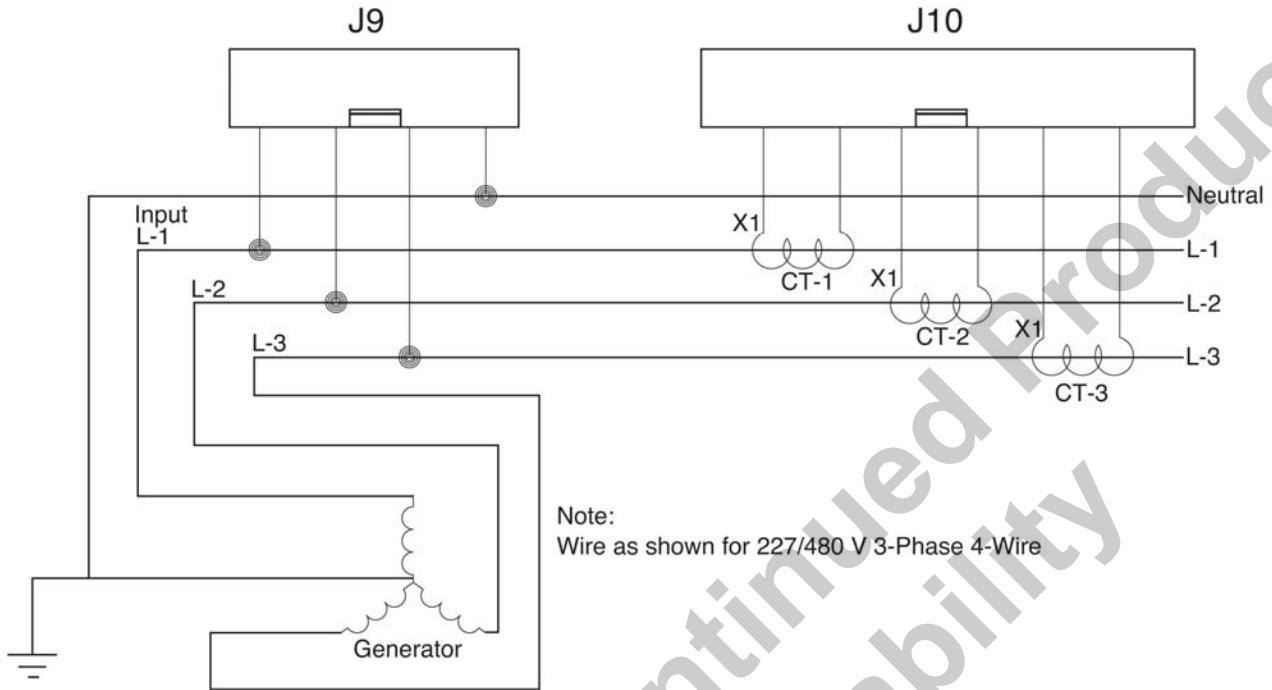

iGUARD Single Phase Wiring

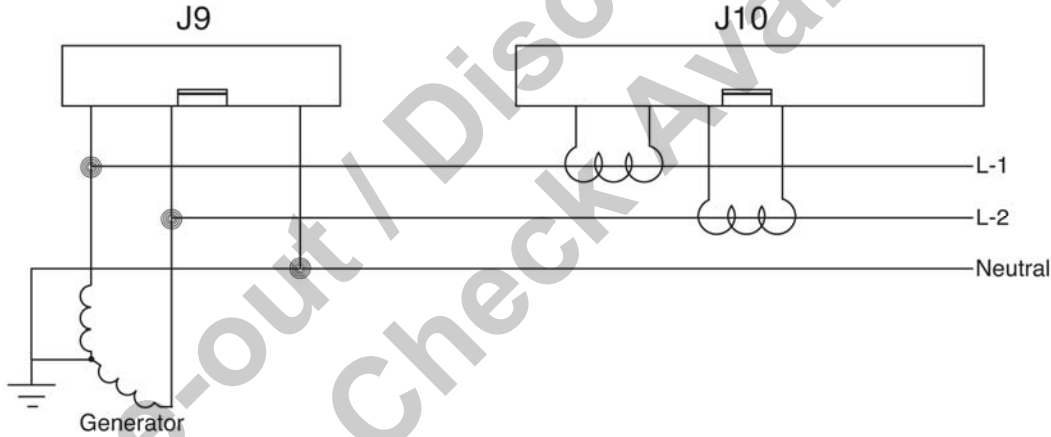

iGUARD In Center Tapped Delta Wiring

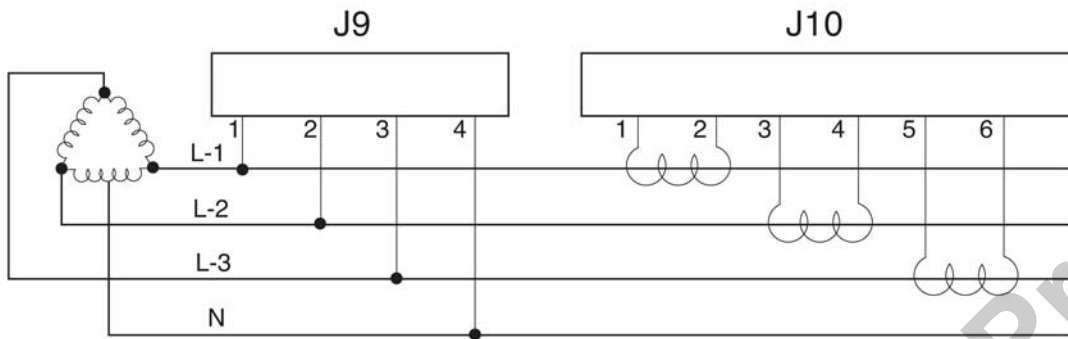

Phase-out / Discontinued Product
Check Availability

iGUARD Sequence Appendix

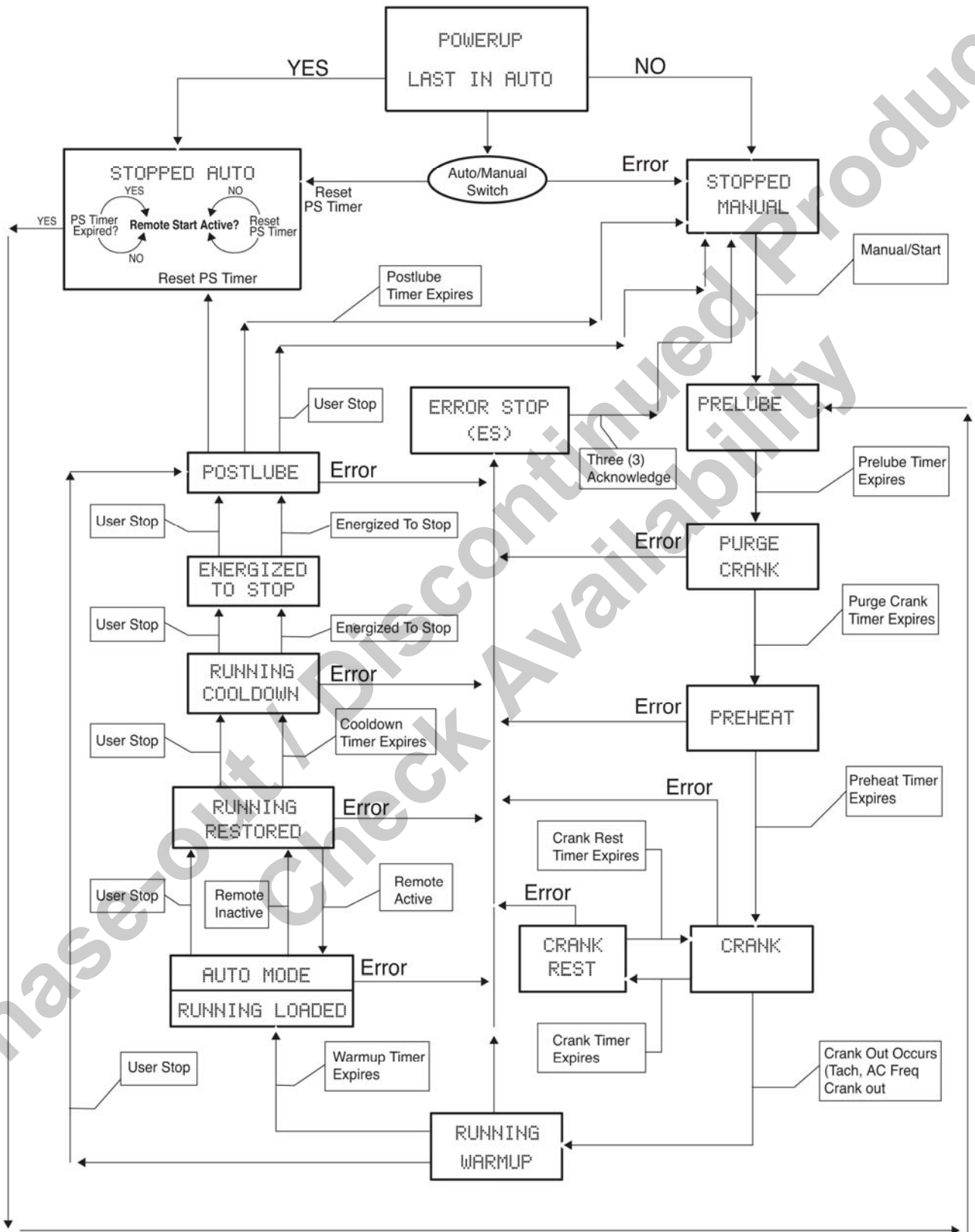

Specifications

Mounting (Cutout) Dimensions:

7.05 x 5.25 x 2.76 in. (179 x 133 x 70 mm).

Mounting Screws: 4, #6-32 screws and nitrile rubber o-ring are supplied to meet NEMA4 specs.

Case Material: Black Polycarbonate, textured finish, UV stabilized.

Connection: 600V rated multi-wire quick connect for DC and AC connections, suitable for wire harnessing.

Power supply: Operates from any DC supply for 8-35VDC continuous. Brownout (5V) ride through is 5 seconds and a total blackout (0V) ride through of 100 milliseconds.

Vibration/Survivability: 3g, 3 axis, frequency swept 10-1000 Hz.

Operating/Storage Temperature Range: -40/+185°F (-40/+85°C).

LCD Operating Range: -4/+176°F (-20/+80°C).

I/O's: Designed to meet NFPA110/NFPA 99 plus offers additional inputs.

Performance Specifications: NFPA110, NFPA 99, SAE Load Dump Test.

Shipping Dimensions: 10 x 9 x 6 in. (254 x 229 x 152 mm).

Shipping Weight: 2 lb. (910 g.).

Standard Components

24 - Digital inputs	1 - RS232 port
7 - Analog inputs	1 - RS485 port
Inputs for up to 3-phases and neutral of AC voltage	1 - RS232/RS485 port
Inputs for 3 CT's for current monitoring	1 - J1939 port
1 - Magnetic pickup input	1 - 64 x 128 pixel full graphic LCD with backlight
8 - 20A Form "C" relays	1 - 12 position keypad

iGUARD Options and Accessories

Wire Harnessing

<i>Part Number</i>	<i>Description</i>
75-00-0074	4-position power connector; 12 ft. (3.65 m) wire leads.
75-00-0075	10-position comm. connector - J1939, RS232, RS485; 12 ft. (3.65 m) wire leads.
75-00-0076	10-position communications connector - RS232, RS485; 12 ft. (3.65 m) wire leads
75-00-0077	Digital Inputs 1 - 8; 12 ft. (3.65 m) wire leads
75-00-0078	Digital Inputs 9 - 24; 12 ft. (3.65 m) wire leads
75-00-0079	Analog Inputs, Magnetic Pickup; 12 ft. (3.65 m) wire leads
75-00-0080	ESD Jumper; 0.2 ft (68 mm) wire leads
75-00-0081	AC Voltage connector; 12 ft. (3.65 m) wire leads
75-00-0082	AC Current connector; 12 ft. (3.65 m) wire leads

Senders and End Devices

<i>Part Number</i>	<i>Description</i>
05-70-1858	0 - 100 psi Oil pressure sender
10-70-2013	300 °F (150°C) Coolant temperature sender
15-70-0116	EL150K1 Oil level indicator and low oil level shutdown
15-70-0104	L129 high/low Oil level indicator and shutdown
15-70-0660	LM2000 Engine oil replenisher and low oil level shutdown
05-70-6345	PXMS-100 4-20mA Pressure sender 100 psi

Current Transformer Options

<i>Part Number</i>	<i>Description</i>
00-00-2592	50:5A Current transformer, 12 inch (305 mm) leads
00-00-2707	60:5A Current transformer, 12 inch (305 mm) leads
00-00-4893	75:5A Current transformer, 12 inch (305 mm) leads
00-00-2372	100:5A Current transformer, 12 inch (305 mm) leads
00-00-2484	150:5A Current transformer, 12 inch (305 mm) leads
00-00-2485	200:5A Current transformer, 12 inch (305 mm) leads
00-00-2486	300:5A Current transformer, 12 inch (305 mm) leads
00-00-2487	400:5A Current transformer, 12 inch (305 mm) leads
00-00-2488	500:5A Current transformer, 12 inch (305 mm) leads
00-00-2489	600:5A Current transformer, 12 inch (305 mm) leads
00-00-2490	800:5A Current transformer, 12 inch (305 mm) leads
00-00-2441	1000:5A Current transformer, 12 inch (305 mm) leads
00-00-2516	1200:5A Current transformer, 12 inch (305 mm) leads
00-00-2517	1500:5A Current transformer, 12 inch (305 mm) leads
00-00-2504	1600:5A Current transformer, 12 inch (305 mm) leads
00-00-2518	2000:5A Current transformer, 12 inch (305 mm) leads
00-00-2519	3000:5A Current transformer, 12 inch (305 mm) leads

MURPHY and the Murphy logo are registered and/or common law trademarks of Murphy Industries, Inc. This document, including textual matter and illustrations, is copyright protected by Murphy Industries, Inc., with all rights reserved. (c) 2011 Murphy Industries, Inc. Other third party product or trade names referenced herein are the property of their respective owners and are used for identification purposes only.

FW MURPHY

P.O. Box 470248
Tulsa, Oklahoma 74147 USA
Phone: +1 918 317 4100 Fax: +1 918 317 4266
E-mail: sales@fwmurphy.com

INDUSTRIAL PANEL DIVISION

Fax: +1 918 317 4124
E-mail: ipdsales@fwmurphy.com

MURPHY POWER IGNITION

Web site: www.murphy-pi.com

CONTROL SYSTEMS & SERVICES DIVISION

P.O. Box 1819
Rosenberg, Texas 77471 USA
Phone: +1 281 633 4500 Fax: +1 281 633 4588
E-mail: css-solutions@fwmurphy.com

FRANK W. MURPHY LTD.

Church Road, Laverstock
Salisbury, SP1 1QZ, UK
Phone: +44 1722 410055 Fax: +44 1722 410088
E-mail: sales@fwmurphy.co.uk
Web site: www.fwmurphy.co.uk

COMPUTRONIC CONTROLS

41 - 46 Railway Terrace
Nechells, Birmingham, B7 5NG, UK
E-mail: sales@computroniccontrols.com
Web site: www.computroniccontrols.com

www.fwmurphy.com

FW MURPHY INSTRUMENTS (HANGZHOU) CO., LTD.

77 23rd Street
Hangzhou Economic & Technological Development Area
Hangzhou, Zhejiang, 310018, China
Phone: +86 571 8788 6060 Fax: +86 571 8684 8878
E-mail: apsales@fwmurphy.com



USA-ISO 9001:2008 FM 28221
UK-ISO 9001:2008 FM 29422
CHINA-ISO 9001:2008 FM 523851
Registered Facilities



Printed in U. S. A.

02/11/2011

Phase-out / Discontinued Product
Check Availability