

# Installation and Operation Manual for Murphy Display and Diagnostic Module (MDDM)



Please read the following information before installing. A visual inspection of this product for damage during shipping is recommended before mounting. It is your responsibility to have a qualified person install this unit and make sure it conforms to NEC and local codes.

## GENERAL INFORMATION

### WARNING

#### BEFORE BEGINNING INSTALLATION OF THIS MURPHY PRODUCT

- ✓ Disconnect all electrical power to the machine.
- ✓ Make sure the machine cannot operate during installation.
- ✓ Follow all safety warnings of the machine manufacturer.
- ✓ Read and follow all installation instructions.



### Description

The Murphy Display and Diagnostic Module (MDDM) is the keystone in a line of components manufactured by FW Murphy as part of its J1939 MurphyLink™ System. The J1939 MurphyLink™ System has been developed to meet the needs for instrumentation and control on electronically controlled engines communicating using the SAE J1939 Controller Area Network (CAN).

The MDDM is a powerful, easy to use multifunction tool that enables the operator to view many different engine parameters and engine service codes. The MDDM includes a two line, eight character backlit LCD display. The top line displays data labels, i.e. "OilPress". The bottom line displays appropriate units information i.e. "80 psi" for oil pressure.

The MDDM has two push buttons (UP and DOWN) for scrolling through the parameter list and viewing the menu list. Two LEDs (amber and red) are used to annunciate active fault messages received by the MDDM.

Other components in the system are microprocessor-based analog gauges for displaying critical engine data broadcast by the ECM: engine RPM, oil pressure, coolant temperature, system voltage, etc., and a combination audible alarm and relay unit for warning and shutdown annunciation.

The MDDM can be connected up to 40 meters from the ECM (Engine Control Module). Up to 32 components may be linked to the MDDM by an RS485 daisy chained twisted pair cable up to 1,000 meters from the MDDM. The MDDM and all connected components can be powered by 12 or 24 volt systems, are back lit using LEDs, and are environmentally sealed.

### How to Order

To order the MDDM use the model number designation diagram below:

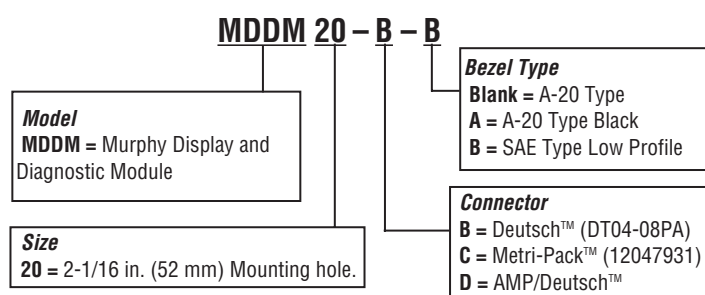

### Engine Parameters

The following are some of the engine parameters displayed by the MDDM in English or Metric units (when applicable):

1. Engine Hours.
2. Engine RPM.
3. System Voltage.
4. % Engine Load at the current RPM.
5. Coolant Temperature.
6. Oil Pressure.
7. Fuel Economy.
8. Throttle Position.
9. Manifold Air Temperature.
10. Current Fuel Consumption.
11. Active Service Codes.
12. Stored Service Codes from the engine.
13. Set the Units for display.
14. View the Engine Configuration Parameters.

### Specifications

**Bezel:** Stainless Steel (Black Optional).

**Membrane Switch:** Polyester.

**Case/Clamp:** Nickel Plated Steel, Aluminum Killed, QQ-S-698.

**Maximum Panel Thickness:** 0.30 inch. (8 mm).

**Mounting Hole:** 2.062 inch (52 mm) in diameter.

**Dial:** White on Black.

**Reversed Polarity:** Withstands reversed battery terminal polarity indefinitely within operating temperatures.

**CAN BUS:** SAE J1939 Compliant.

**Auxiliary Gage Communication:** RS485.

**Operating Voltage:** 8 VDC Minimum to 32 VDC Maximum.

**Operating Temperature:** -4 to 158°F (-20 to 70°C).

**Storage Temperature:** -40 to 185°F (-40 to 85°C).

## Typical Mounting Dimensions



**WARNING:** Disconnect negative battery cable before mounting.



**IMPORTANT:** The MDDM display is best viewed either straight on or at the 6 o'clock position

### Panel Mounting

Remove the mounting bracket and insert the gage from the front side of the panel. Replace bracket and secure it (12-16 in./lb. torque), do **NOT** overtighten. (See Figure below).

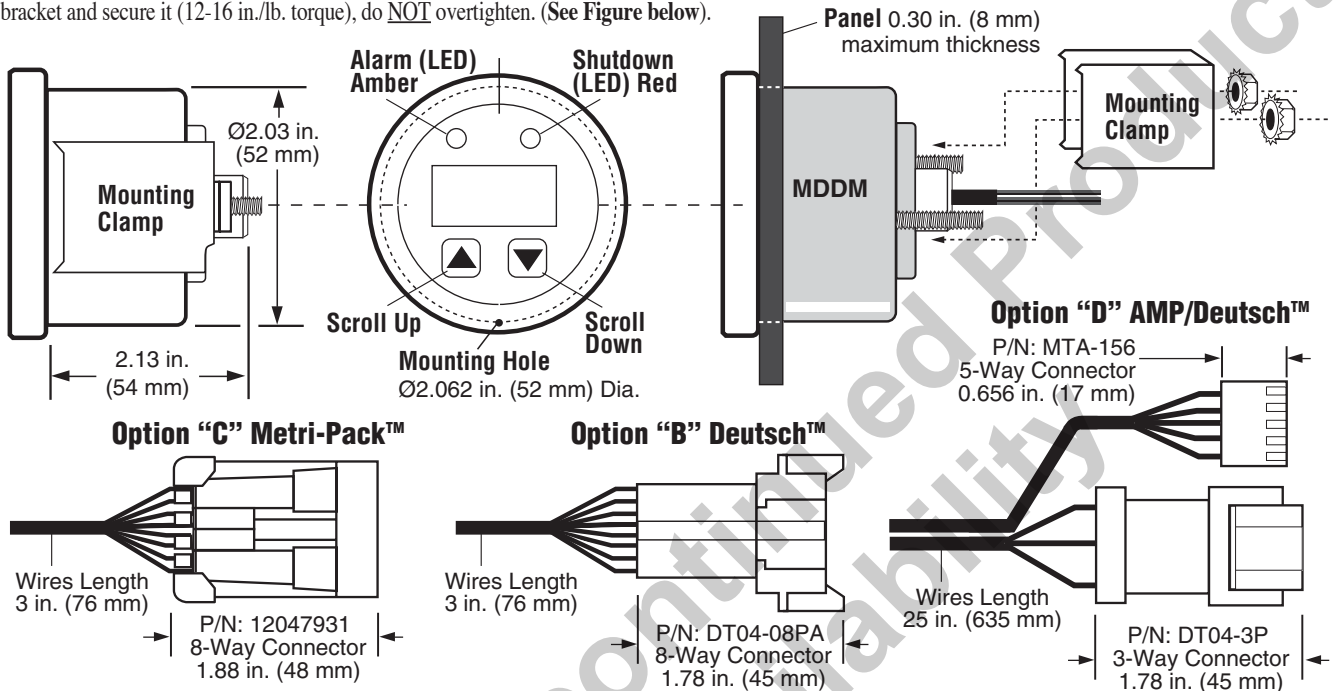

## MDDM Typical Wiring Diagram



**IMPORTANT:** To eliminate external interference: RS485(+) and RS485(-) should be twisted pair cable or twist wires together, one twist per inch minimum. CAN\_L, CAN\_H and CAN Shield should be approved J1939 CAN bus cable or twist wires, one twist per inch min.

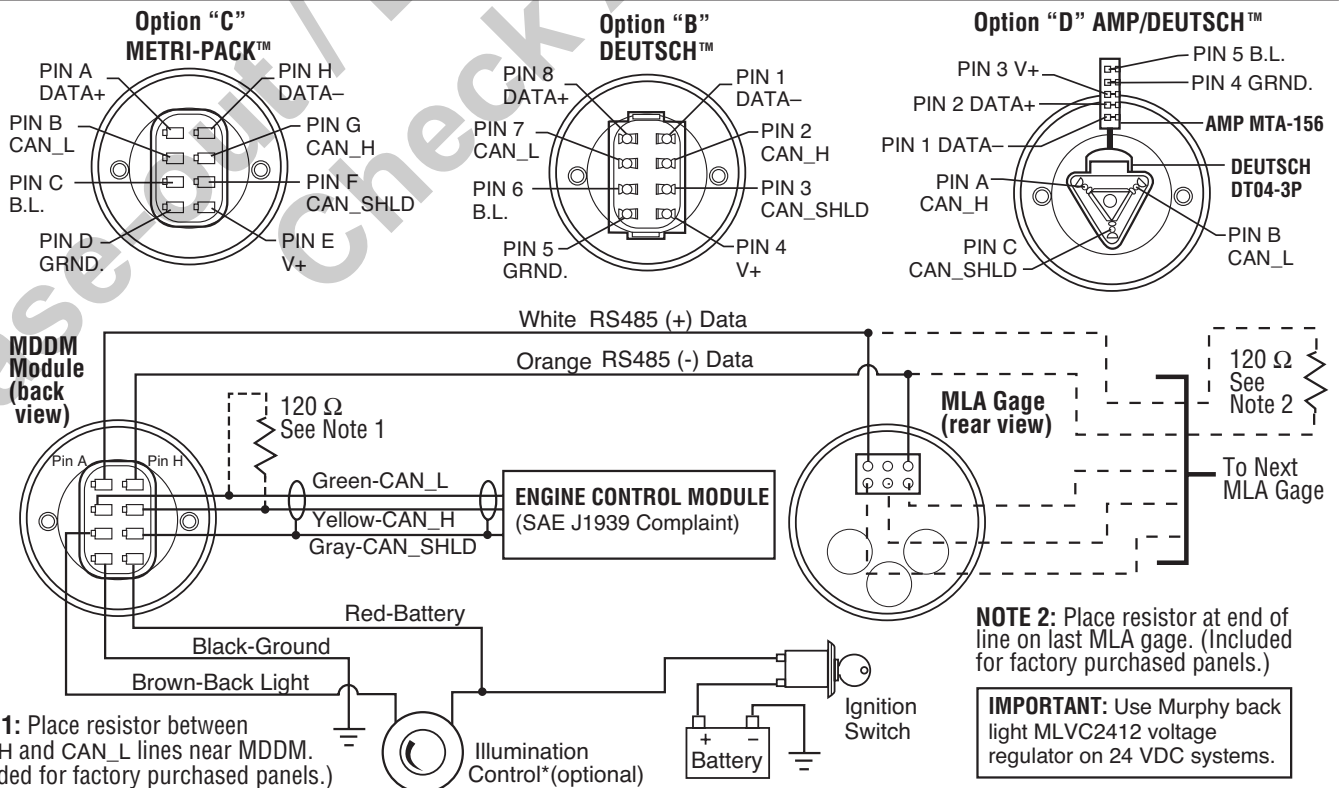

**NOTE 1:** Place resistor between CAN\_H and CAN\_L lines near MDDM. (Included for factory purchased panels.)

**NOTE 2:** Place resistor at end of line on last MLA gage. (Included for factory purchased panels.)

**IMPORTANT:** Use Murphy back light MLVC2412 voltage regulator on 24 VDC systems.

## Operating Instructions

The MDDM is simple to use and allows quick and easy navigation through the menu structure to find the information needed.

The MDDM Main Menu Tree (below) first displays engine data parameters, followed by the sub-menu entry points.

**NOTE:** When first powered up some unused parameters may be displayed by the MDDM. These parameters will be automatically removed from the display after the initialization cycle is complete.

The following two rules are used for accessing the various items on the main menus:

1. To scroll through the parameter list, press either the UP or Down push buttons.
2. To select or exit a sub-menu **SIMULTANEOUSLY** press the UP and DOWN push buttons.

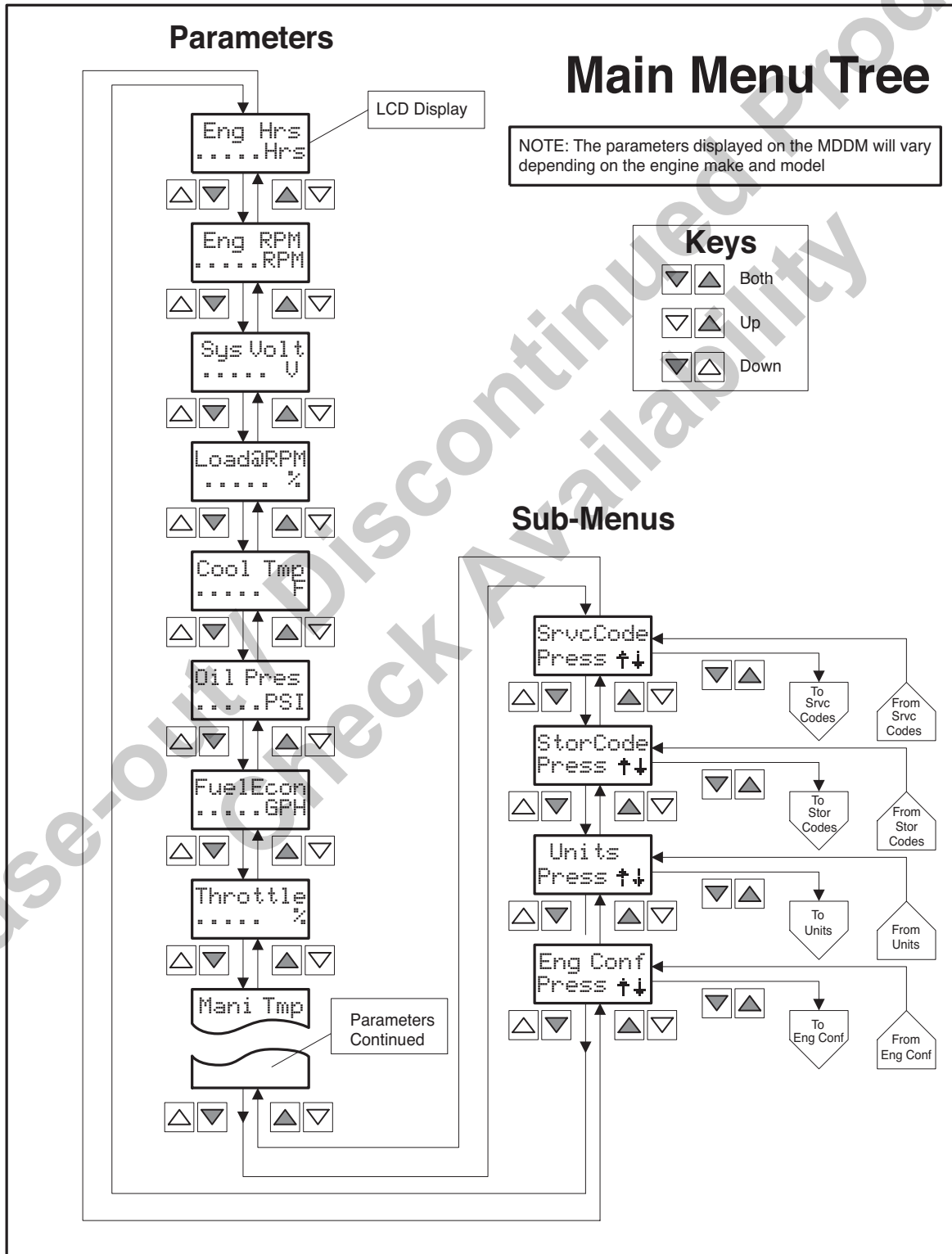

## Selecting Engine Data Parameters

To read any of the engine parameters press either the UP or DOWN button until the top line of the display shows the desired information.

## Selecting Sub-Menus

Press either the UP or DOWN button until the top line of the display shows the label of the desired Sub-Menu. Then press BOTH the UP and DOWN buttons SIMULTANEOUSLY. This action will select the Sub-Menu and the next screen on the display will list the Sub-Menu items.

## Changing Units of Measure

The MDDM can display engine data in either English or Metric units.

To select English or Metric, the Units Sub-Menu must be selected. To select the Units Sub-Menu, press the UP or DOWN button until the display shows the following label:



Press BOTH the UP and DOWN buttons SIMULTANEOUSLY to select the Units Sub-Menu. The Units Sub-Menu Figure (below) shows the steps for selecting the desired units of measure. Two options are available:

1. Press BOTH buttons to retain the current units designation.
2. Press either UP or DOWN button to toggle the units selection, then press BOTH buttons to select the desired unit of measure.

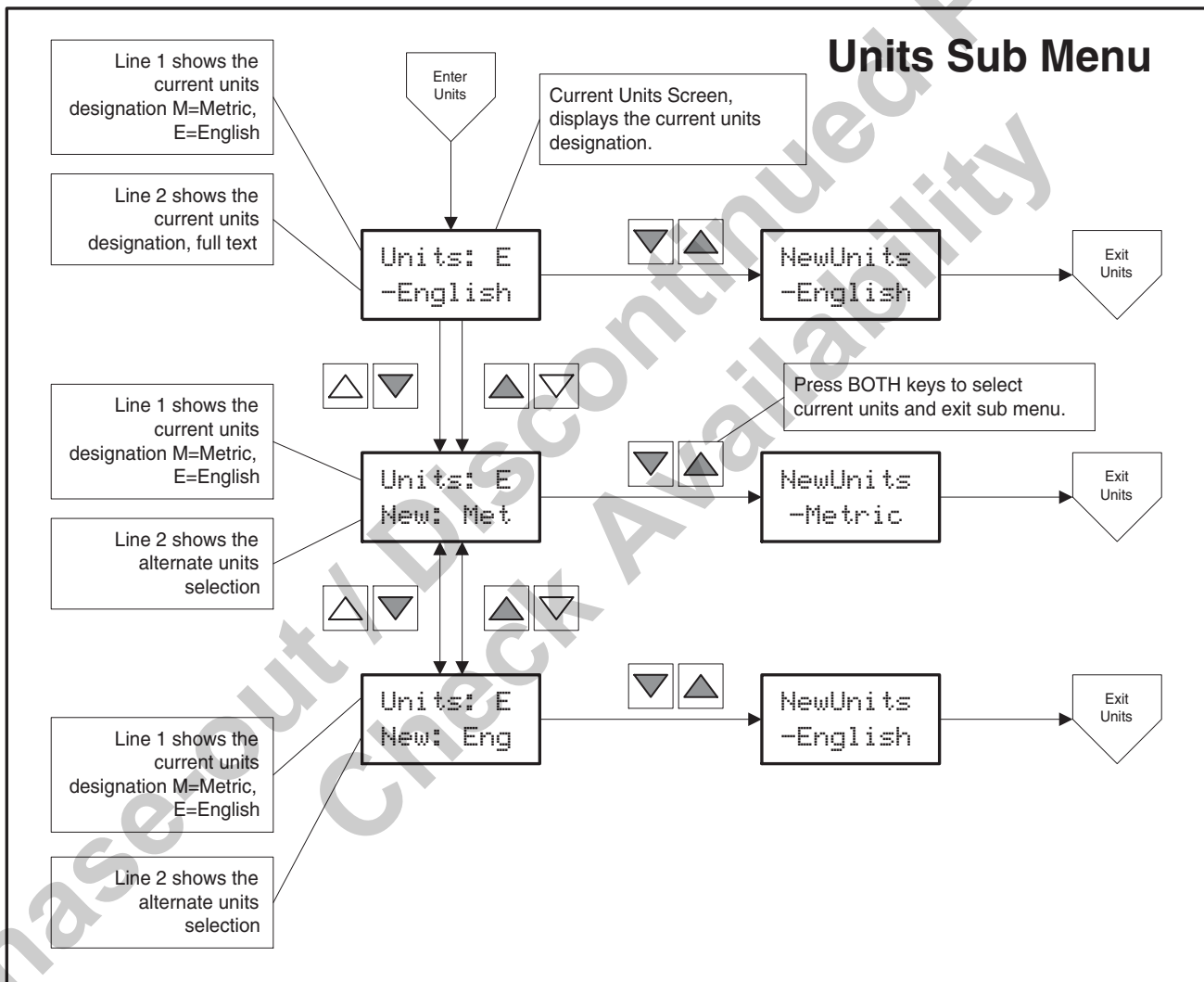

### Viewing Engine Configuration Data

The MDDM can display the engine configuration data stored in the engine ECM. To select the Engine Configuration Sub-Menu (shown below), press the UP or DOWN button until the display shows the following label.



Press **BOTH** the UP and DOWN buttons **SIMULTANEOUSLY** to select the Engine Configuration Sub-Menu. The MDDM will display the engine configuration data as shown in Engine Configuration Sub-Menu. If the Engine Configuration is not available, the display will show:



NOTE: The parameters displayed on the MDDM will vary depending on the engine make and model

### Engine Configuration Sub-Menu

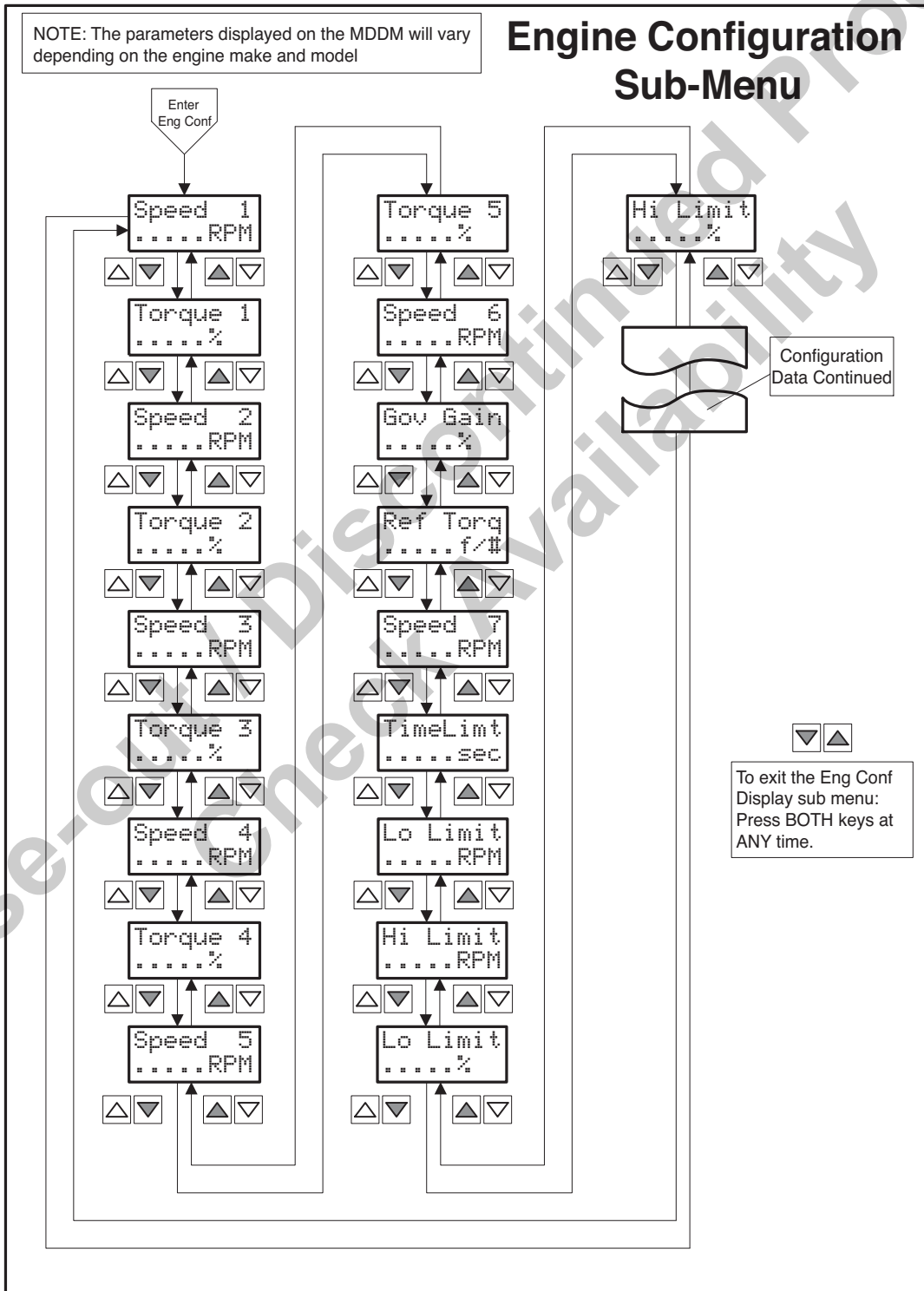

### Viewing Active Engine Service Codes

The MDDM continuously monitors all messages broadcast over the SAE J1939 Control Area Network (CAN) and displays all Active Service Codes at the time the message is broadcast. When a fault occurs the display will show the message "SrvcCode" every five seconds interrupting the currently displayed parameter. In addition, the amber LED will be illuminated during Active Service Code warning faults, and the red LED will be illuminated during shut-down faults. These warnings will continue until the fault clears.

To view the Active Service Codes select the Service Code Sub-Menu by pressing the UP or DOWN button until the display shows the following label:



Press both the UP and DOWN buttons SIMULTANEOUSLY to select the Service Code Sub-Menu. The MDDM will display all Active Service Codes as shown in the Service Codes Menu schematic (below). If Service Codes are not available, the display will show the following:

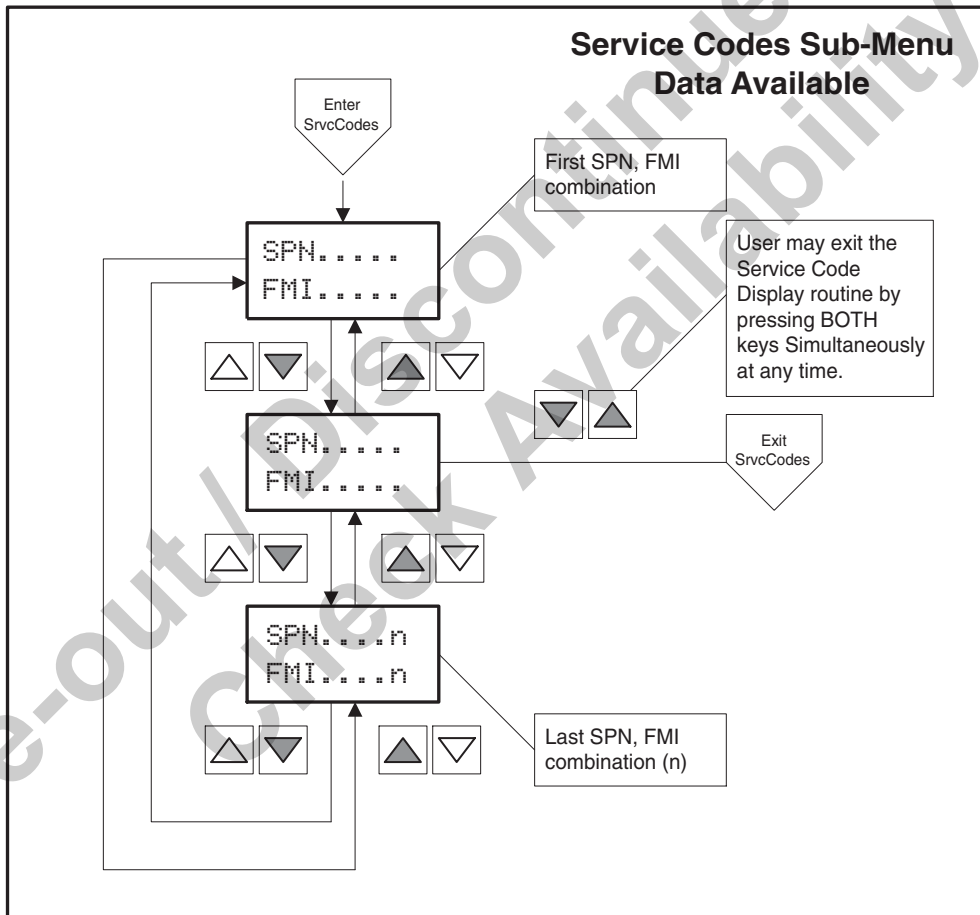
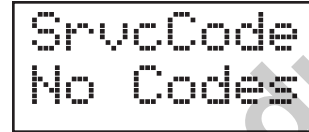

### Explanation of SPN & FMI Diagnostic Codes

SPN refers to Suspect Parameter Number and FMI refers to Failure Mode Identifier. Both the SPN and FMI are used in the J1939 standard for identification of faults and conditions.

## Viewing Service Codes in The Engine Control Module (ECM)

The MDDM can request Stored Service Codes (DM2) from the engine. The Stored Service Codes may be used for diagnostic and service needs. To view the Stored Service Codes it is necessary to select the StorCode Sub-Menu by pressing the UP or DOWN button until the display shows the following label.

```
StorCode
Press ↑↓
```

Press both the UP and DOWN buttons SIMULTANEOUSLY to select the StorCodes Sub-Menu. The MDDM will display the Stored Service Codes according to the menus shown in the schematic below.

If Stored Service Codes are not available, the display will show:

```
StorCode
No Data
```

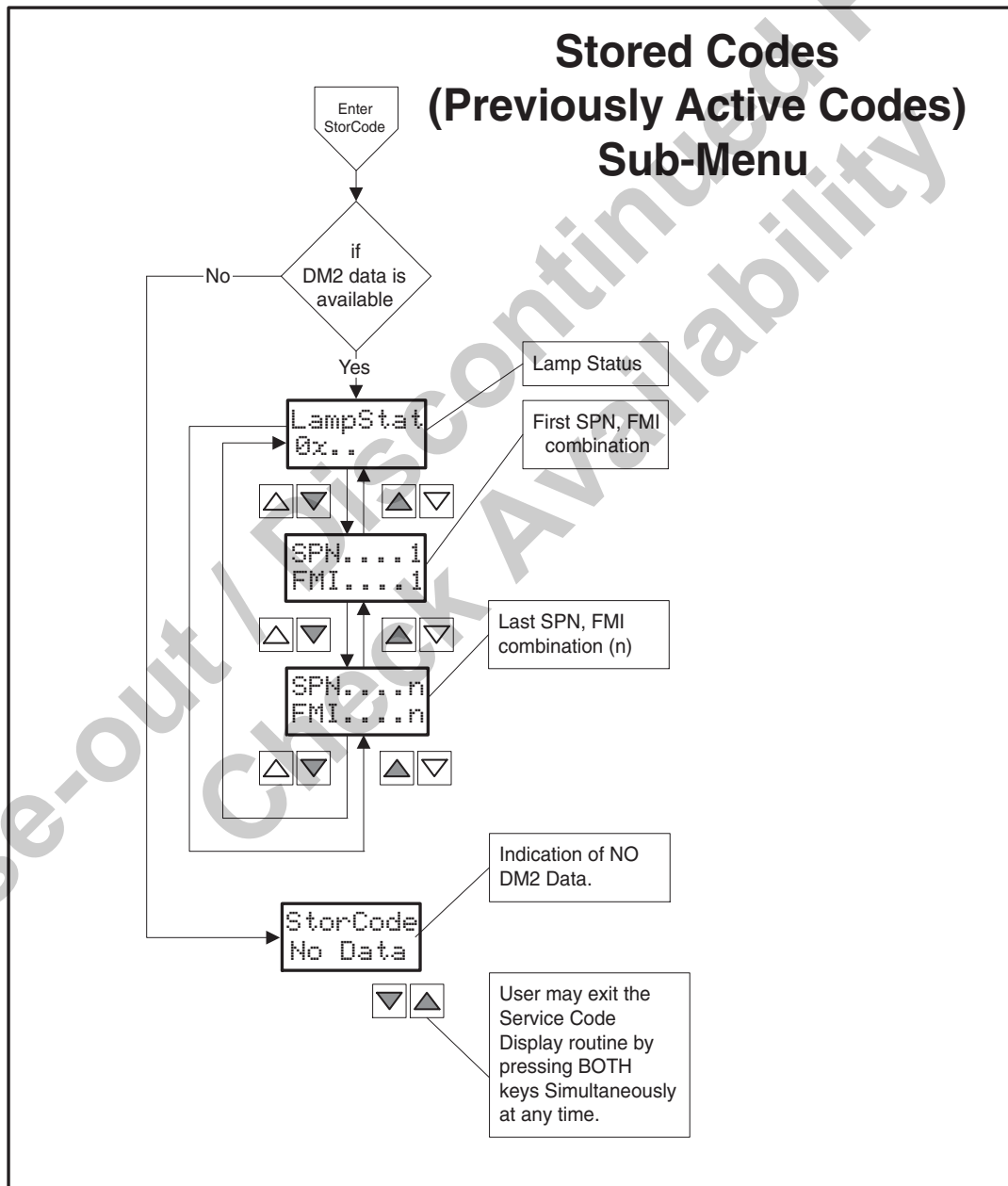

## SAE J1939 MurphyLink System Implementation of J1939 Parameters

Source: SAEJ1939-71 Surface Vehicle Recommended Practice

SAE J1939 Section	Description	PGN	Parameter	Display Value
5.3.6	Elec Eng Cont #2 - EEC2	61443	Accelerator Pedal Position Percent Load at Current RPM	Throttle Load@RPM
5.3.7	Elec Eng Cont #1 - EEC1	61444	Actual engine % torque Engine Speed	Eng Torq Eng RPM
5.3.14	Vehicle Distance	65248	Trip Distance Total Vehicle Distance	TripDist Veh Dist
5.3.19	Engine hours, Revolutions	65253	Total Engine Hours	Eng Hrs
5.3.23	Fuel Consumption	65257	Trip Fuel Total Fuel Used	TripFuel FuelUsed
5.3.28	Engine Temperature	65262	Engine Coolant Temp Fuel Temperature Engine Oil Temperature Engine Intercooler Temperature	Cool Tmp Fuel Tmp Oil Tmp Intc Tmp
5.3.29	Engine Fluid Level/Pressure	65263	Fuel Delivery Pressure Engine Oil Level Engine Oil Pressure Coolant Pressure Coolant Level	FuelPres Oil Lvl Oil Pres CoolPres Cool Lvl
5.3.31	Cruise Control /Vehicle Speed	65265	Wheel Based Vehicle Speed	Veh Spd
5.3.32	Fuel Economy	65266	Fuel Rate Instantaneous Fuel Economy Average Fuel Economy	FuelRate FuelEcon Avg Econ
5.3.35	Ambient Conditions	65269	Barometric Pressure Air Inlet Temperature	BaroPres AirInTmp
5.3.36	Inlet/Exhaust Conditions	65270	Boost Pressure Intake Manifold Temp Air Filter Differential Pressure Exhaust Gas Temperature	Bst Pres Mani Tmp AirDifPr Exh Tmp
5.3.37	Vehicle Electrical Power	65271	Electrical Potential (Voltage) Battery Pot. Voltage (Switched)	Sys Volt Bat Volt
5.3.38	Transmission Fluids	65272	Transmission Oil Pressure Transmission Oil Temperature	TranPres Tran Tmp
5.3.46	Engine Fluid Level/Pressure #2	65243	Injector Metering Rail 1 Pres Injector Metering Rail 2 Pres	InjPres1 InjPres2
5.3.58	Fan Drive	65213		Fan Spd
	Diagnostic Messages	65226 65227 65228	DM1 - Active Diagnostic DM2 - Previously Act Diag Codes DM3 - Diagnostic Clear	SrvcCode StorCode

### Warranty

A limited warranty on materials and workmanship is given with this FW Murphy product.  
A copy of the warranty may be viewed or printed by going to [www.fwmurphy.com/support/warranty.htm](http://www.fwmurphy.com/support/warranty.htm)



**FW Murphy**  
P.O. Box 470248  
Tulsa, Oklahoma 74147 USA  
+1 918 317 4100  
fax +1 918 317 4266  
e-mail [sales@fwmurphy.com](mailto:sales@fwmurphy.com)  
[www.fwmurphy.com](http://www.fwmurphy.com)

**CONTROL SYSTEMS & SERVICES DIVISION**  
P.O. Box 1819; Rosenberg, Texas 77471; USA  
+1 281 633 4500 fax +1 281 633 4588  
e-mail [sales@fwmurphy.com](mailto:sales@fwmurphy.com)

**MURPHY DE MEXICO, S.A. DE C.V.**  
Blvd. Antonio Rocha Cordero 300, Fracción del Aguaje  
San Luis Potosí, S.L.P.; México 78384  
+52 444 8206264 fax +52 444 8206336  
Villahermosa Office +52 993 3162117  
e-mail [ventas@murphymex.com.mx](mailto:ventas@murphymex.com.mx)  
[www.murphymex.com.mx](http://www.murphymex.com.mx)

**FRANK W. MURPHY, LTD.**  
Church Rd.; Laverstock, Salisbury SP1 1QZ; U.K.  
+44 1722 410055 fax +44 1722 410088  
e-mail [sales@fwmurphy.co.uk](mailto:sales@fwmurphy.co.uk)  
[www.fwmurphy.co.uk](http://www.fwmurphy.co.uk)

**MURPHY SWITCH OF CALIFORNIA**  
41343 12th Street West  
Palmdale, California 93551-1442; USA  
+1 661 272 4700 fax +1 661 947 7570  
e-mail [sales@murphyswitch.com](mailto:sales@murphyswitch.com)  
[www.murphyswitch.com](http://www.murphyswitch.com)

**MACQUARRIE CORPORATION**  
1620 Hume Highway  
Campbellfield, Vic 3061; Australia  
+61 3 9358 5555 fax +61 3 9358 5558  
e-mail [murphy@macquarrie.com.au](mailto:murphy@macquarrie.com.au)



*In order to consistently bring you the highest quality, full featured products, we reserve the right to change our specifications and designs at any time.*

# MDDM TROUBLESHOOTING

For the MDDM to display engine parameter information, the ECM (Engine Control Module) must be programmed to broadcast J1939 information over the CAN (Controller Area Network). Most ECMs are pre-programmed from the factory to broadcast J1939 information. please verify that the ECM is "J1939 Enabled".

The MDDM must have a "Termination Resistor" across the CAN\_L and CAN\_H wires to read J1939 information, see page 2 "MDDM typical Wiring Diagram".

## **MDDM INTERNAL ERROR CODES**

### **Address Claim Procedure Errors (ACP-Err):**

As a part of the MDDM's boot up procedure, the MDDM must claim a network address for its use. If an error occurs during this procedure an error code is displayed on the LCD.

#### **Error Code 1.**

Line 1: "ACP-Err"  
Line 2: "No Addr"

This error occurs if the MDDM is NOT able to claim an address, either the default address or one of the addresses from its range of addresses (43 - 127). If this error occurs the MDDM has tried EACH address in it's range and has lost arbitration with each. Therefore, the MDDM has not claimed an address.

#### **Error Code 2.**

Line 1: "ACP-Err"  
Line 2: "Bus EP"

This error occurs if the MDDM encounters a CAN bus error that has caused the MDDM's bus interface to transition into an error state of operation. The "Bus EP " means that the MDDM is in a Error Passive (EP) mode. The Error Passive state is a result of the MDDM not having a partner on the CAN bus, or the MDDM is attached to the CAN bus with the CAN\_HI and CAN\_LO reversed.

#### **Error Code 3.**

Line 1: "ACP-Err"  
Line 2: "BusError"

This error occurs if the MDDM has transitioned through the Error Passive mode and has continued to encounter CAN bus errors. The "BusError" mode is a result of catastrophic errors on the CAN bus, some possible causes:

- CAN\_HI or CAN\_LO or both are shorted to electrical ground or to the battery voltage
- One or more nodes on the CAN bus is transmitting at a non-standard baud rate.

This type of error is generally non-recoverable, and will require a skilled service person to help sort out the possible error causes.

### **Run Time Bus Errors:**

After the MDDM has claimed a network address, it enters its run time mode of operation. If a bus error occurs during this mode, one of the following error codes will be displayed.

#### **Error Code 1.**

Line 1: "xxxxx EP"  
Line 2: "No Data"

EP = Error Passive, for some reason the MDDM has lost contact with the network and no longer has a communications partner or partners. This may have been caused by a connector separating, or the network wires being severed.

#### **Error Code 2.**

Line 1: "xxxxx BO"  
Line 2: "No Data"

BO = Bus Off, see ACP Error Code #3.

#### **Error Code 3.**

Line 1: "xxxxx BR"  
Line 2: "No Data"

BR = Bus Reset, this error code is similar to ACP error code #3. The MDDM has encountered CAN bus errors that have caused it to transition through EP, and BO, in this state the MDDM is resetting the CAN interface in an attempt to re-establish connection to the network.