



# Tachometer and Tach/Hourmeter Installation Instructions

## Series: ATS, ATHS, ATA, ATHA, ATHI

Please read the following instructions before installing. A visual inspection is recommended before mounting. General Information and these installation instructions are intended for all Tachometer and Tachometer/Hourmeter models.

### GENERAL INFORMATION

## WARNING

BEFORE BEGINNING INSTALLATION OF THIS MURPHY PRODUCT

- ✓ Disconnect all electrical power to the machine.
- ✓ Make sure the machine cannot operate during installation.
- ✓ Follow all safety warnings of the machine manufacturer.
- ✓ Read and follow all installation instructions.

### Description

These tachometers are indicators of engine revolutions per minute (RPM). Models equipped with hourmeter also record elapsed engine running time.

Alternator driven models function from pulses generated by an alternator with 4, 8, 12, 14, or 16 poles on the rotor. For magnetic sensor (pickup) driven models, the pulses are obtained from the ring gear of an engine's flywheel (having from 70 to 225 teeth) using an electromagnetic sensor (pickup).

Ignition signal driven models available for 4, 6 and 8 cylinder, spark ignited engines.

All units are for negative ground, positive ground or isolated electrical systems. If the instrument is connected reverse polarity, it will not operate until proper connections are made. All units are powered by 12 VDC. For 24 VDC applications, an optional ATVC12/24 converter must be used (see Fig. 3 or Fig. 5).

### Specifications

**Power Input:** 12 VDC (11.5 – 16 V) [0.84 to 1.44W].

**Backlight:** 3 to 4.7W

**RPM Input Signal Voltage:** 1.5 Vrms minimum from a magnetic pickup or alternator (minimum 3-pole).

**Accuracy:** Tachometer:  $\pm 2\%$  full scale. Hourmeter:  $\pm 0.01\%$  hours,  $\pm 1$  count.

**Temperature Range:**  $-5^{\circ}\text{F}$  to  $185^{\circ}\text{F}$  ( $-20^{\circ}\text{C}$  to  $+85^{\circ}\text{C}$ ).

**Dial (Face Plate):**  $270^{\circ}$  sweep with white numerals (over black background)

**Bezel:** 304 Stainless Steel.

**Scale:** 0-3000 RPM and 0-4000 RPM (ATHA-40-12-A model only)

**Case Material:** Plastic.

**Hourmeter Range:** Measures elapsed time: 100,000 hours in 0.1 increments.

### Models

**Magnetic Sensor Tachometer 3000 RPM; 70 - 225 pulses 12 VDC**

Model #	Designation
ATS-30-12	Bright Stainless Steel Bezel
ATS-30-12-A	Black Stainless Steel Bezel
ATS-30-12-B	SAE Bright Stainless Steel Bezel
ATS-30-12-C	SAE Black Stainless Steel Bezel

**Magnetic Sensor Tach/Hourmeter 3000 RPM; 70 - 225 pulses 12 VDC**

ATHS-30-12	Bright Stainless Steel Bezel
ATHS-30-12-A	Black Stainless Steel Bezel
ATHS-30-12-B	SAE Bright Stainless Steel Bezel
ATHS-30-12-C	SAE Black Stainless Steel Bezel

**Alternator Signal Tachometer 3000 RPM; 3 - 27 pulses 12 VDC**

ATA-30-12	Bright Stainless Steel Bezel
ATA-30-12-A	Black Stainless Steel Bezel
ATA-30-12-B	SAE Bright Stainless Steel Bezel
ATA-30-12-C	SAE Black Stainless Steel Bezel

**Alternator Signal Tach/Hourmeter 4000 RPM; 3 - 27 pulses 12 VDC**

ATHA-30-12	Bright Stainless Steel Bezel
ATHA-30-12-A	Black Stainless Steel Bezel
ATHA-30-12-B	SAE Bright Stainless Steel Bezel
ATHA-30-12-C	SAE Black Stainless Steel Bezel

ATHA-40-12-A Black Stainless Steel Bezel

**Ignition Signal Tach/Hourmeter 4000 RPM; 4, 6 or 8 cylinder 12 VDC**

ATHI-40-12-A Black Stainless Steel Bezel

### Optional Items and Replacement Bulbs

ATVC12/24	24 VDC to 12 VDC Converter
00-00-4617	12 VDC Light Bulb
00-00-4618	24 VDC Light Bulb

For a selection of Magnetic Sensors (pickups) see installation instructions document MP-8802N.

### Case Mounting Instructions

Mount these units in a place where they will be protected from rain and splashing water. A minimum distance of 12 in. (305 mm) from any coil, coil leads, or high voltage wiring should be maintained. These units are intended for mounting in a flat

panel. Cut a 3-3/8 in. (86 mm) diameter hole as shown below. Remove the mounting bracket from the back of the unit. Insert the instrument from the front side of the panel and replace the mounting bracket to secure the instrument in place.

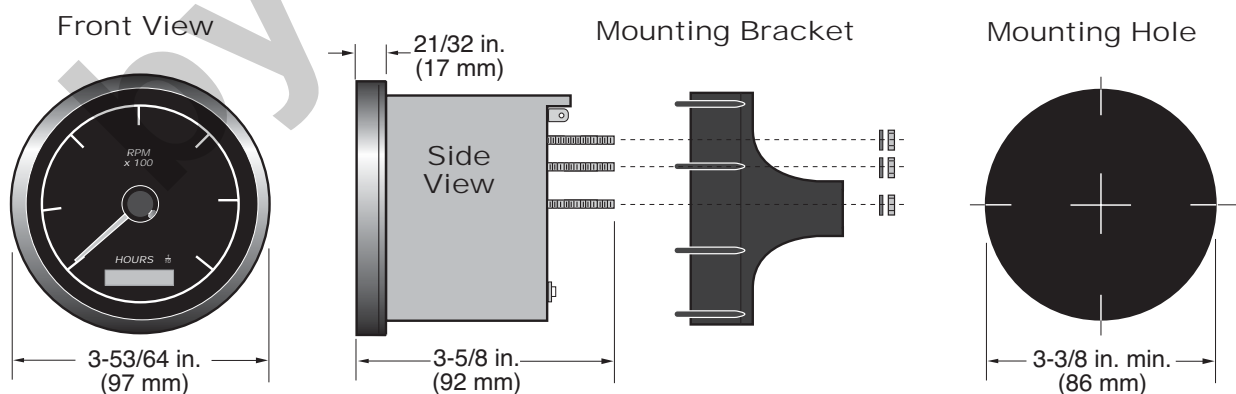

## Mounting Requirements

**Fig. 1**

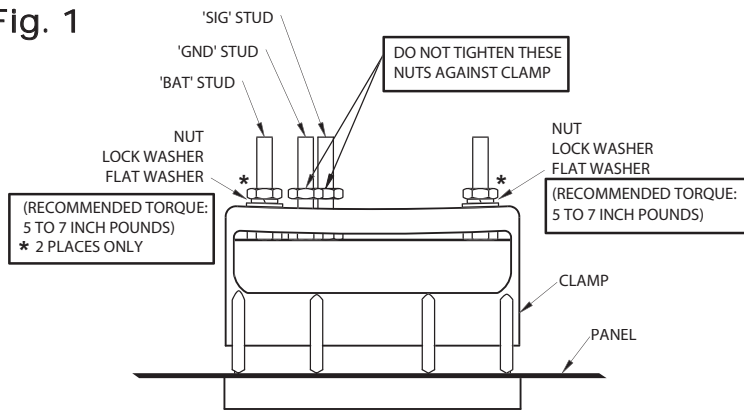

**Fig. 1A**

**WHEN USING ATVC12/24  
24-Volt converter card  
Make Sure Nuts Are  
Level Under Card**

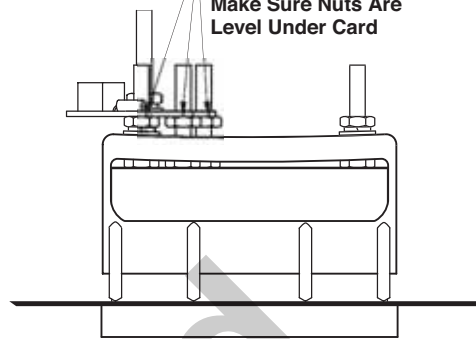

## ATS and AHS Series Models Typical Wiring



# CAUTION



Devices containing solid state components can be damaged or caused to malfunction when used in systems which incorporate inductive loads (e.g. relays, solenoids, etc.) that can generate reverse voltage spikes. To reduce the potential for this type of damage, install a properly sized fly-back or clamping diode across all inductive loads.

Shown at right is a typical example:

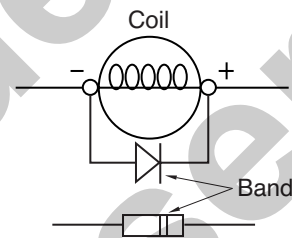

A typical diode is 1N4005 which is readily available from commercial sources. Failures of this type are not covered by our Limited Warranty.



**CAUTION: Disconnect the battery/power source and determine voltage and polarity of the application before wiring the unit. Use the appropriate wire size. To wire the magnetic sensor pickup use 18 AWG (1.0 mm<sup>2</sup>) twisted pair cable. Use insulated crimp-on (solderless) ring-type wire terminals. Allow a few inches of excess wire to make adjustments.**

### Connecting or Replacing Light Bulb

1. Twist the "light assembly" socket one-eighth turn counterclockwise and remove the "light assembly". See Fig. 2 at right.
2. To replace the bulb, pull the bulb from the socket and replace with an 00-00-4617 (for 12V), 00-00-4618 (for 24V) bulb or equivalent size as marked on the bulb.
3. Connect the lamp blade connector to (+) positive side of instrument lighting circuit.

### Connecting to Magnetic Sensor (see Fig. 2)

The magnetic sensor (pickup) usually has two connections (terminals or wires) exiting from it. These connections are not polarized, either connection can be considered (+) positive or (-) negative signal. These two connections must be routed directly to the unit. Do NOT ground one of the connections at the engine.

1. Connect one of the wires in the twisted pair (from magnetic sensor) to "SIG".
2. Connect the other the wire in the twisted pair (from the magnetic sensor) to "GND".

### Connecting to Power (see Fig. 2)

*Important: These units are for 12 VDC only.*

1. Connect a wire from "BAT" to a 12 VDC circuit activated by the ignition switch.
2. Connect a wire from "GND" to negative voltage source (electrical ground).

### Connecting ATVC12/24 Converter (see Fig. 3)

For 24 VDC applications, a ATVC12/24 converter must be used.

1. Insert the ATVC12/24 converter as shown in Fig. 3, at right.
2. Secure the ATVC12/24 converter with a nut on the "BAT" and "GND" stud terminals of the Tachometer.
3. Notice that the stud terminal on the ATVC12/24 converter becomes the "BAT" stud for connecting to 24 VDC. Proceed with the connection as shown.
4. Replace the 12 V bulb with the 24 V bulb supplied with the converter assembly.

**Fig. 2**

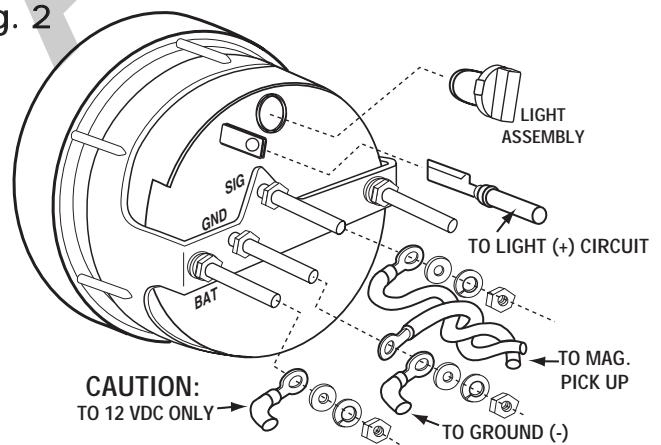

**Fig. 3**

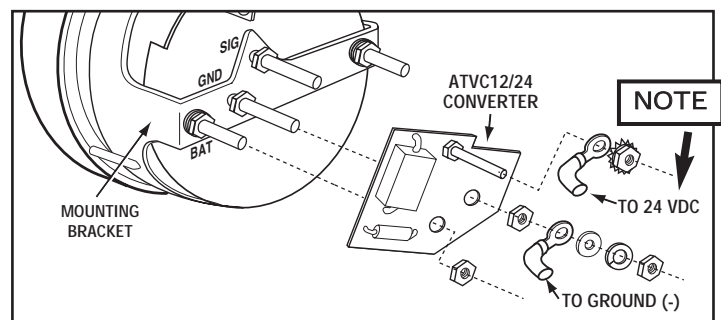

## Typical Wiring For ATA And ATHA Series Models



**CAUTION:** Disconnect the battery/power source and determine voltage and polarity of the application before wiring the unit. Use the appropriate wire size. It is recommended using 16 AWG (1.5 mm<sup>2</sup>) or larger stranded, insulated wire and insulated crimp-on (solderless) ring-type wire terminals. Allow a few inches of excess wire to make adjustments.

### Connecting or Replacing Light Bulb

1. Twist the "light assembly" socket one-eighth turn counterclockwise and remove the "light assembly". See Fig. 4 at right.
2. To replace the bulb, pull the bulb from the socket and replace with an 00-00-4617 (for 12V), 00-00-4618 (for 24V) bulb or equivalent size as marked on the bulb.
3. Connect the lamp blade connector to (+) positive side of instrument lighting circuit.

Fig. 4

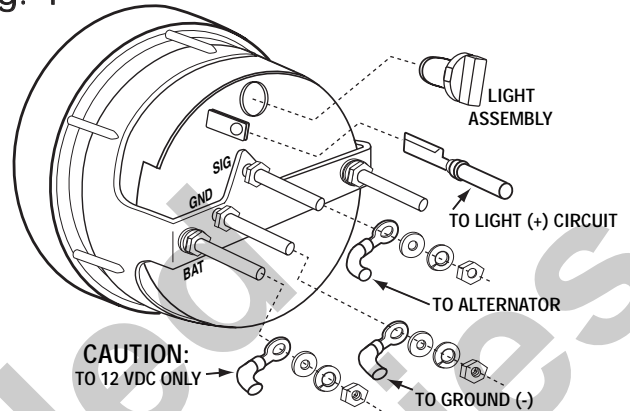

### Connecting to Alternator (see Fig. 4)

1. Connect a wire from "SIG" terminal an AC phase terminal (sometimes marked "STA" or "R") on your alternator. If your alternator does not have an AC phase terminal, solder the "SIG" wire to one of the negative or positive rectifier diodes of the alternator.
2. After soldering, securely tape the wire to an alternator lead or wiring harness to dampen vibration on diode terminal. **NOTE:** On some alternators it may be necessary to remove the rear housing to solder the wire to the diode.

### Connecting to Ignition (see Fig. 4)

1. Connect a wire from "SIG" terminal to the negative "-" side of the igniton coil or to the terminal marked "TACH" on solid-state ignition systems.

### Connecting to Power (see Fig. 4)

**Important:** These units are for 12 VDC only.

1. Connect a wire from "BAT" to a 12 VDC circuit activated by the ignition switch.
2. Connect a wire from "GND" to negative voltage source (electrical ground).

### Connecting ATVC12/24 Converter (see Fig. 5)

For 24 VDC applications, a ATVC12/24 convertor must be used.

1. Insert the ATVC12/24 convertor as shown.
2. Secure the ATVC12/24 convertor with a nut on the "BAT" and "GND" stud terminals of the Tachometer.
3. Notice that the stud terminal on the ATVC12/24 convertor becomes the "BAT" stud for connecting to 24 VDC. Proceed with the connection as shown.
4. Replace the 12 V bulb with the 24 V bulb supplied with the converter assembly.

Fig. 5

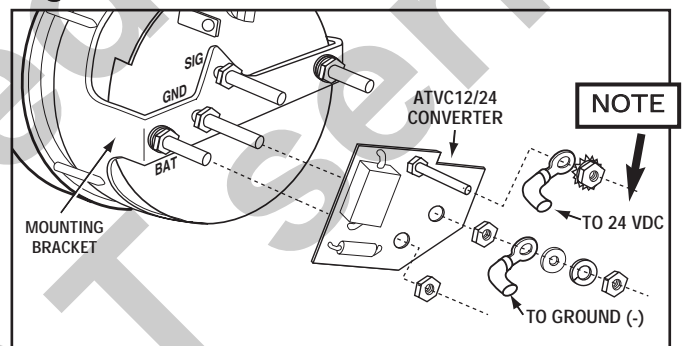

## Calibration Instructions

### Calibration for ATS and ATHS models

The ATS and ATHS Series models have been designed to function with flywheels having anywhere from 70 to 225 teeth. This wide range is divided into 6 switched positions acting as a "coarse adjustment" as follows:

Switch Position	Range of Flywheel Teeth
1	70 - 80 teeth
2	81 - 100 teeth
3	101 - 130 teeth
4	131 - 160 teeth
5	161 - 190 teeth
6	191 - 225 teeth

1. If the number of teeth on the flywheel is known, set the calibration "coarse adjustment switch", (see Fig. 6, at right), using a fine blade slotted head screwdriver to the applicable position per chart above.
2. If the number of teeth on the flywheel is not known, set up a calibrated "shop tach" to monitor the engine's true RPM. Start the engine and after an appropriate warm-up period increase to normal running RPM as read on the shop tach. If the course switch was not set in step 1, set it now to the position that causes the Murphy tach to read closest to true RPM.\*

\* Some engines incorporate a governor that limits full throttle RPM to pre-set level equal to the engine's recommended maximum running speed. If your engine has such a governor, and if the governed full throttle RPM is known (it should be clearly stated on the engine's certification documentation), use of a calibrated shop tach is not necessary. Simply run the engine up to governed maximum running RPM and calibrate the Murphy tach to the rated RPM as specified in the engine's certification documentation.

**WARNING:** Make sure that the engine has a properly functioning and certified governor before attempting this alternate procedure.

### Fine Adjustment for ATS and ATHS models

The "fine adjustment" of calibration is accomplished by varying the calibration Trimpot located behind the "fine adjustment" access hole on the rear of the case, (see Fig. 6, below). Proceed with calibration as follows:

1. To adjust the trimpot for accurate RPM, punch through the label and insert a 1/16 x 1-3/4 in. flat blade Screwdriver (Sears item #00941659000/Mfr. model #504-062C) or a #000 phillips screwdriver through the access hole and into the fine adjustment trim pot.
- \*Note it is typically necessary to rotate the screwdriver to locate the trim pot slot orientation.
2. Rotate the trimpot clockwise or counterclockwise as necessary.
3. Once calibration at the engine's normal running RPM has been set, the tach will simultaneously be calibrated at all other engine speeds.

Fig. 6

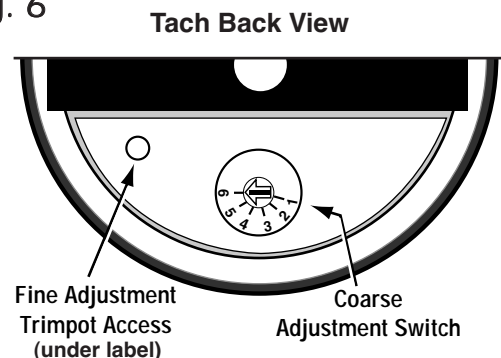

## Calibration for ATA and ATHA models

The ATA and ATHA Series models will operate from 3 to 27 pulses per engine revolution. Obtain the number of pulses per engine revolution for your alternator system by working the following formulas:

1. Determine the number of poles on your alternator. Look for the designation/type in the manufacturer's manual or remove the pulley and fan to count the number of poles on the rotor.
2. The **ALTERNATOR TACHOMETER CHART** lists common alternators and their minimum and maximum pulley ratios. Determine pulley ratio with the following formula:

$$\text{PULLEY RATIO} = \frac{\text{CRANK SHAFT PULLEY DIAMETER}}{\text{ALTERNATOR PULLEY DIAMETER}}$$

3. Check that Pulley Ratio falls within the range shown on the **PULLEY RATIOS CHART** for a particular alternator. If ratio falls in the shaded area, the tachometer can be calibrated for the application.
4. To determine the pulses per engine revolution:

$$\frac{\text{NUMBER OF POLES}}{2} \times \text{PULLEY RATIO} = \text{PULSES PER ENGINE REVOLUTION}$$

5. If your answer falls between:
  - 3 and 4.5 set "coarse adjustment switch" to #1.
  - 4.55 and 6.0, set the switch to #2.
  - 6.05 and 8.5, set the switch to #3.
  - 8.55 and 12.0, set the switch to #4.
  - 12.05 and 18.0, set the switch to #5.
  - 18.05 and 27.0, set the switch to #6.

## Fine Adjustment for ATA and ATHA models

The "fine adjustment" of calibration is accomplished by varying the calibration Trimpot located behind the "fine adjustment" access hole on the rear of the case, (see Fig.7, below). Proceed with calibration as follows:

1. To adjust the trimpot for accurate RPM, punch through the label and insert a 1/16 x 1-3/4 in. flat blade Screwdriver (Sears item #00941659000/Mfr. model #504-062C) or a #000 phillips screwdriver through the access hole and into the fine adjustment trim pot.

\*Note it is typically necessary to rotate the screwdriver to locate the trim pot slot orientation.

2. Rotate the trimpot clockwise or counterclockwise as necessary.

## PULLEY RATIOS CHART

NO. OF POLES	RATIO										Minimum	Maximum
	0.5	1.5	2.0	2.5	3.0	3.5	4.0	4.5	5.0			
4											1.5	13
8											0.75	6.5
12											0.5	4.3
14											0.42	3.7
16											0.375	3.25

## ALTERNATOR TACHOMETER CHART

Manufacturer	Designation/Type	Poles	Minimum pulley-ratio	Maximum* pulley-ratio
Prestolite	All	8	0.75	6.5
Load Handler	88A, 8LHA, 89C, 8LHC	16	0.375	3.25
Load Handler	All 5 inch models	12	0.5	4.3
Leece Neville	All	12	0.5	4.3
Bosch	G and K Series	12	0.5	4.3
C.E. Neilhoff	All	12	0.5	4.3
Delco Remy	30DN	4	1.5	13
Delco Remy	15SI, 21SI, 40DN, 40SI	12	0.5	4.3
Delco Remy	10DN, 10SI, 12SI	14	0.42	3.7
Delco Remy	20DN, 25SI, 27SI	16	0.375	3.25
Delco Remy	29SI, 30SI	16	0.375	3.25
Hitachi	LT125, LT130, LT133	8	0.75	6.5
Hitachi	LT150	12	0.5	4.3
Lucas	All	12	0.5	4.3
Mando	All	12	0.5	4.3
Motorcraft	All	12	0.5	4.3
Nippondenso	All	12	0.5	4.3
Powerline	Series 23	14	0.42	3.7
Powerline	Series 24, 25, 26	12	0.5	4.3
Valeo	All	12	0.5	4.3

\* Although the tach may be calibrated for higher input frequencies in some cases, as shown on the Pulley Ratio chart, pulley ratios in excess of 5.0 are NOT recommended nor are they normally used.

Fig. 7 Tach Back View

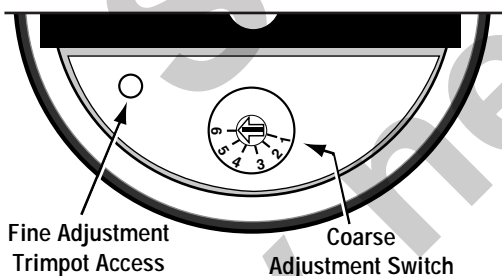

## ATHI Models Typical Wiring and Calibration Instructions



**CAUTION:** Disconnect the battery/power source and determine voltage and polarity of the application before wiring the unit. Use the appropriate wire size. It is recommended using 16 AWG (1.5 mm<sup>2</sup>) or larger stranded, insulated wire and insulated crimp-on (solderless) ring-type wire terminals. Allow a few inches of excess wire to make adjustments.

### Connecting or Replacing Light Bulb

1. Twist the "light assembly" socket one-eighth turn counterclockwise and remove the "light assembly". See Fig. 4 at right.
2. To replace the bulb, pull the bulb from the socket and replace with an 00-00-4617 (for 12V), 00-00-4618 (for 24V) bulb or equivalent size as marked on the bulb.
3. Connect the lamp blade connector to (+) positive side of instrument lighting circuit.

### Connecting to Ignition (see Fig. 8)

1. Connect a wire from "SIG" terminal to the negative (-) side of the igniton coil or to the terminal marked "TACH" on solid-state ignition systems.

### Connecting to Power (see Fig. 8)

*Important: These units are for 12 VDC only.*

1. Connect a wire from "BAT" to a 12 VDC circuit activated by the ignition switch.
2. Connect a wire from "GND" to negative voltage source (electrical ground).

### Connecting ATVC12/24 Converter (see Fig. 9)

For 24 VDC applications, a ATVC12/24 converter must be used.

1. Insert the ATVC12/24 converter as shown.
2. Secure the ATVC12/24 converter with a nut on the "BAT" and "GND" stud terminals of the Tachometer.
3. Notice that the stud terminal on the ATVC12/24 converter becomes the "BAT" stud for connecting to 24 VDC. Proceed with the connection as shown.
4. Replace the 12 V bulb with the 24 V bulb supplied with the converter assembly.

### Calibration for ATHI models

The ATHI Series models have been designed to function from the ignition signal on 4, 6 or 8 cylinder engines. Set the "coarse adjustment switch" per the following table:

Engine	Switch Position
4 cyl.	1
6 cyl.	2
8 cyl.	3

No fine adjustment is necessary.

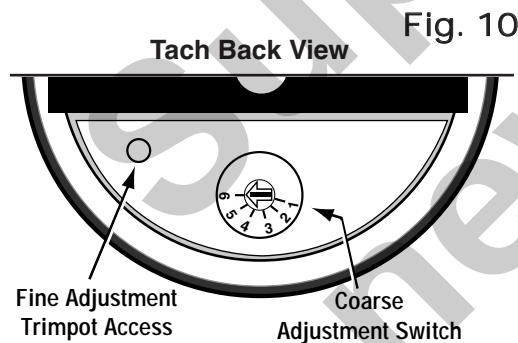

Fig. 8

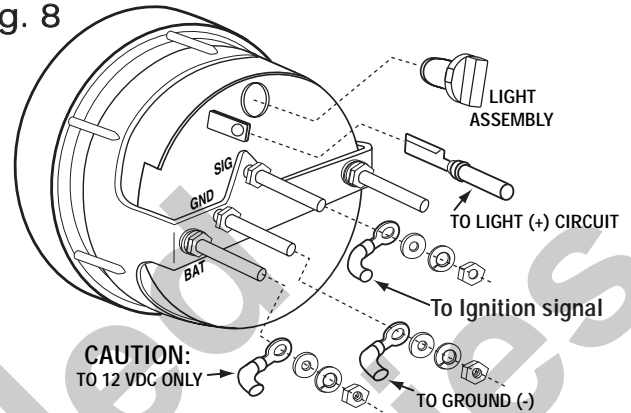
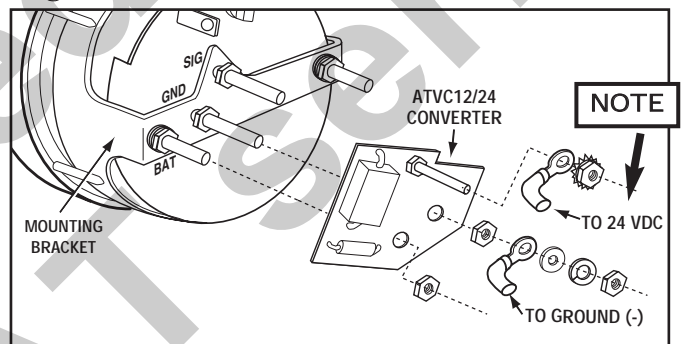

Fig. 9



### Warranty

A limited warranty on materials and workmanship is given with this FW Murphy product. A copy of the warranty may be viewed or printed by going to [www.fwmurphy.com/support/warranty.htm](http://www.fwmurphy.com/support/warranty.htm)

**FW MURPHY**  
P.O. Box 470248  
Tulsa, Oklahoma 74147 USA  
+1 918 317 4100 Fax: +1 918 317 4266  
E-mail: [sales@fwmurphy.com](mailto:sales@fwmurphy.com)

**INDUSTRIAL PANEL DIVISION**  
Fax: +1 918 317 4124  
E-mail: [ipdsales@fwmurphy.com](mailto:ipdsales@fwmurphy.com)

**MURPHY POWER IGNITION**  
Web site: [www.murphy-pi.com](http://www.murphy-pi.com)

[www.fwmurphy.com](http://www.fwmurphy.com)

**CONTROL SYSTEMS & SERVICES DIVISION**  
P.O. Box 1819  
Rosenberg, Texas 77471 USA  
Phone: +1 281 633 4500 Fax: +1 281 633 4588  
E-mail: [sales@fwmurphy.com](mailto:sales@fwmurphy.com)

**FRANK W. MURPHY, LTD**  
Church Rd Laverstock  
Salisbury SP1 1QZ UK  
Phone: +44 172 241 0055 Fax: +44 172 241 0088  
E-mail: [sales@fwmurphy.co.uk](mailto:sales@fwmurphy.co.uk)  
Web site: [www.fwmurphy.co.uk](http://www.fwmurphy.co.uk)

**COMPUTRONIC CONTROLS, LTD**  
41 - 43 Railway Terrace Nechells  
Birmingham B7 5NG UK  
Phone: +44 121 327 8500 Fax: +44 121 327 8501  
E-mail: [info@computroniccontrols.com](mailto:info@computroniccontrols.com)  
Web site: [www.computroniccontrols.com](http://www.computroniccontrols.com)

**FW MURPHY INSTRUMENTS (HANGZHOU) CO. LTD**  
77 23rd Street  
Hangzhou Economic & Technological Development Area  
Hangzhou, Zhejiang 310018 China  
Phone: +86 571 8788 6060 Fax: +86 571 8684 8878



Printed in U.S.A.